

















Model name	Model cycle	Model name	Model cycle
 Audi 80		 A3	
Audi 80 / S2	1990 – 1995	A3 / S3 (3-door)	1996 – 2003
Audi 80 / S2 / RS2 Avant	1992 – 1995	A3 (5-door)	1999 – 2003
Audi 80 / S2 Coupé	1988 – 1996	A3 / S3 (3-door)	2003 – 2012
Audi 80 Cabriolet	1991 – 2000	A3 / S3 / RS3 Sportback	2004 – 2012
		A3 Cabriolet	2008 – 2013
		A3 / S3 (3-door)	from 2012
		A3 / S3 Sportback	from 2012
		A3 Sportback g-tron	from 2013
		A3 Sportback e-tron	from 2014
		A3 / S3 Limousine	from 2013
		A3 / S3 Cabriolet	from 2013
 Audi 100			
Audi 100	1988 – 1991		
Audi 100 Avant	1988 – 1991		
Audi 100 / A6 / S6	1991 – 1997		
Audi 100 / A6 / S6 Avant	1991 – 1997		
 Audi 200		 A4	
Audi 200 / V8	1984 – 1991	A4 / S4	1995 – 2001
Audi 200 Avant	1985 – 1991	A4 / S4 / RS4 Avant	1996 – 2001
		A4 / S4	2001 – 2005
		A4 / S4 Avant	2001 – 2005
		A4 / S4 / RS4	2005 – 2007
		A4 / S4 / RS4 Avant	2005 – 2008
		A4 / S4 Cabriolet	2002 – 2005
		A4 / S4 / RS4 Cabriolet	2005 – 2009
		A4 / S4	2007 – 2012
		A4 / S4 Avant	2008 – 2012
		A4 allroad	2009 – 2012
		A4 / S4	from 2012
		A4 / S4 / RS4 Avant	from 2012
		A4 allroad	from 2012
 A1			
A1 / S1	from 2010		
A1 e-tron	from 2011		
A1 / S1 Sportback	from 2012		
 A2			
A2	2000 – 2005		

Continued on next page 

Model Overview

Audi

Model name	Model cycle	Model name	Model cycle
 A5 A5 / S5 / RS5 A5 / S5 Cabriolet A5 / S5 Sportback A5 / S5 / RS5 A5 / S5 / RS5 Cabriolet A5 / S5 Sportback	2007 – 2011 2009 – 2011 2009 – 2011 from 2011 from 2011 from 2011	 Q3 Q3 / RS Q3	from 2011
 A6 A6 / S6 / RS6 A6 / S6 / RS6 Avant A6 allroad A6 / S6 / RS6 A6 / S6 / RS6 A6 / S6 / RS6 Avant A6 allroad A6 / S6 A6 / S6 / RS6 Avant A6 allroad A6 hybrid	1997 – 2004 1998 – 2004 2001 – 2006 2004 – 2008 2008 – 2011 2004 – 2012 2006 – 2012 from 2011 from 2011 from 2012 from 2012	 Q7 Q7	from 2006
 A7 A7 / S7 / RS7 Sportback	from 2010	 R8 R8 R8 Spyder	from 2007 from 2010
 A8 A8 / S8 A8 / S8 A8 / S8 A8 hybrid	1994 – 2002 2002 – 2010 from 2010 from 2012	 TT TT Coupé TT Roadster TT / TTS / TTRS Coupé TT / TTS / TTRS Roadster TT / TTS Coupé TT / TTS Roadster	1998 – 2006 1999 – 2006 2006 – 2014 2007 – 2014 from 2014 from 2014

Legal Disclaimer:

This manual has been created exclusively for rescuers who have been specially trained in the area of providing emergency rescue after automobile accidents and who are therefore qualified to use the activities described in this manual. Furthermore, this manual shows the maximum possible equipment specification in the model overview.

Vehicle specifications and special options as well as Audi model availability are constantly subject to change. Therefore, Audi reserves the right to change the content of this manual at all times.

Please note: The information contained in this manual is not intended for customers or for repair shops and dealers. Customers may gather detailed information from their vehicle owner's manual regarding vehicle function as well as any occupant safety features and system descriptions.

Repair shops and dealers obtain repair information through their normal channels.

(Status: 11/2014)



Hint:

The maximum possible equipment specification is always shown in the model overview.

You will find "Rescue and Recovery involving Audi Vehicles" in a separate part of the same title.

The creation of this Rescue Data sheets is supported by Moditech Rescue Solutions (www.moditech.com). The vehicle overviews in the attachment are also included in interactive form in the data base "Crash Recovery System".





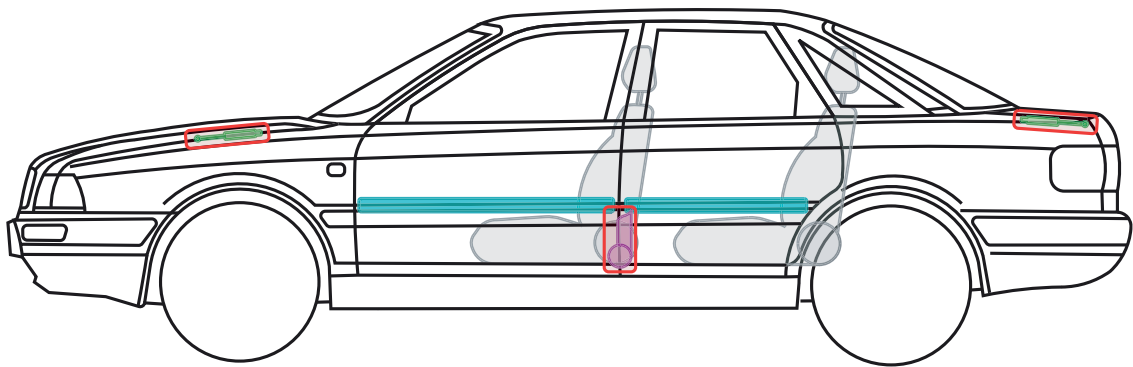
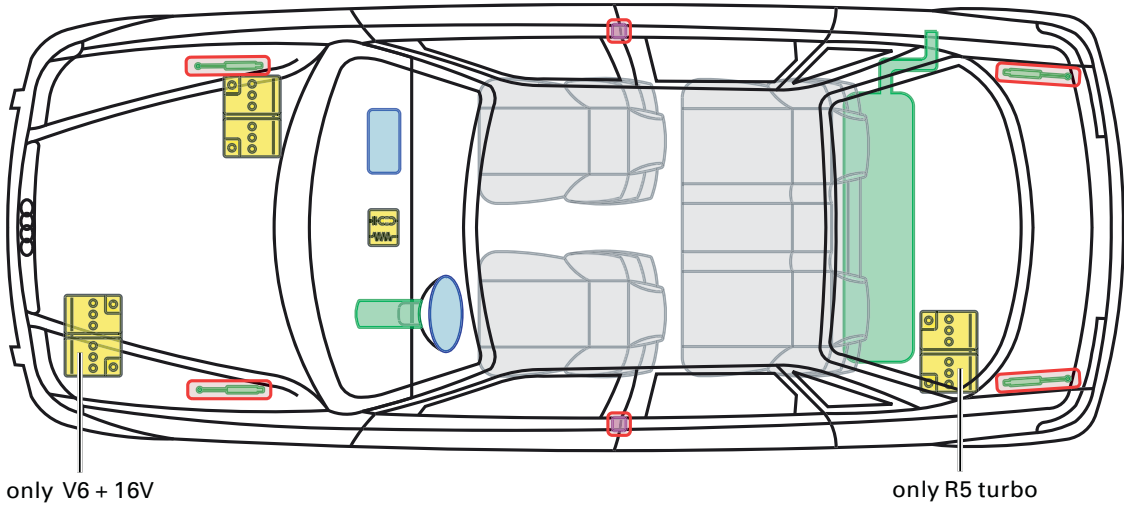

This document is a subject to the copyright of AUDI AG, Ingolstadt. Any duplication, distribution, storage, communication, broadcast and reproduction or transmission of the contents without written approval from AUDI AG is prohibited.

Audi 80 / S2

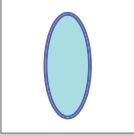
1990 – 1995

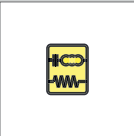
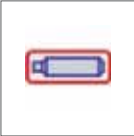

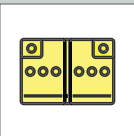
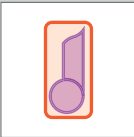
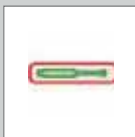
Legend

	Airbag		Reinforce-ment		Control module
	Gas generator		Rollover protection		Battery
	Pretensioner		Gas-pressure damper		Fuel tank

This document is a subject to the copyright of AUDI AG, Ingolstadt. Any duplication, distribution, storage, communication, broadcast and reproduction or transmission of the contents without written approval from AUDI AG is prohibited.



▶ Audi 80 / S2 / RS2 Avant

1992 – 1995

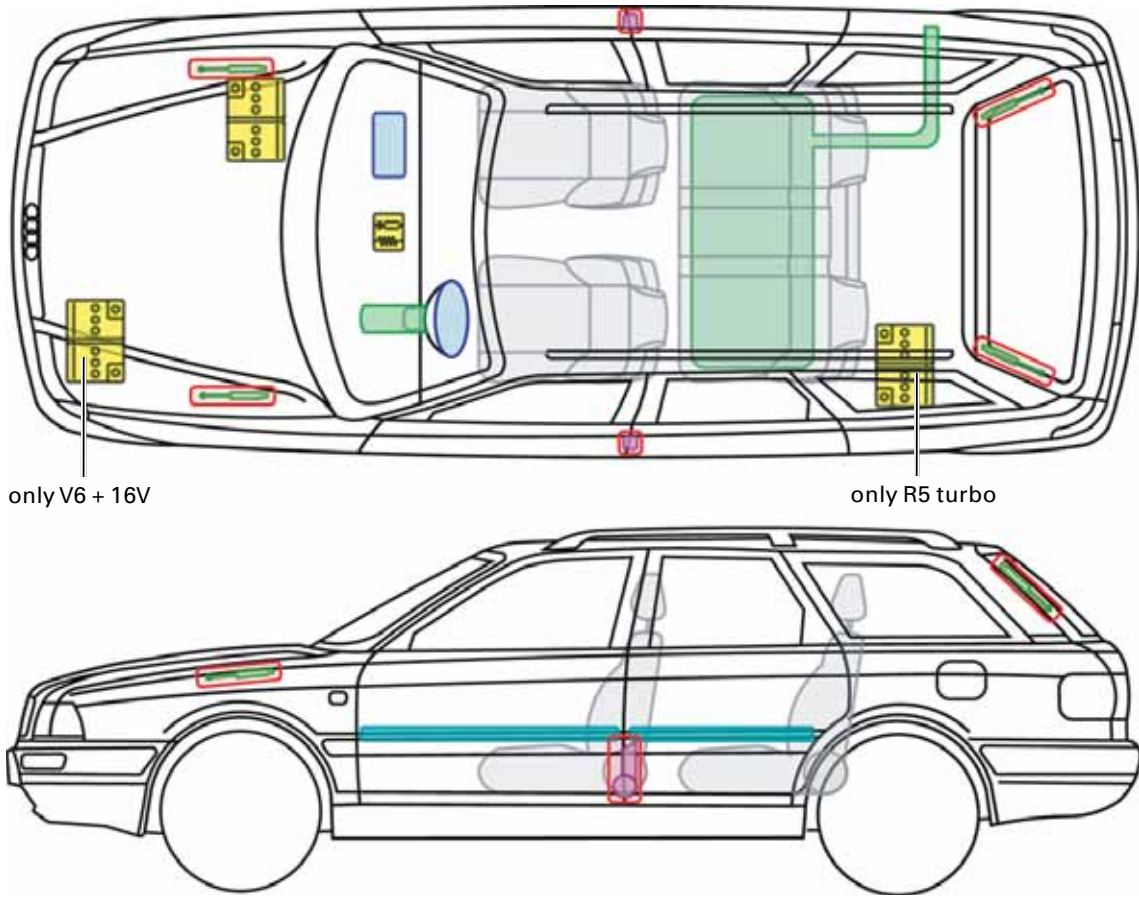

Legend

	Airbag		Reinforcement		Control module
	Gas generator		Rollover protection		Battery
	Pre-tensioner		Gas-pressure damper		Fuel tank

This document is a subject to the copyright of AUDI AG, Ingolstadt. Any duplication, distribution, storage, communication, broadcast and reproduction or transmission of the contents without written approval from AUDI AG is prohibited.







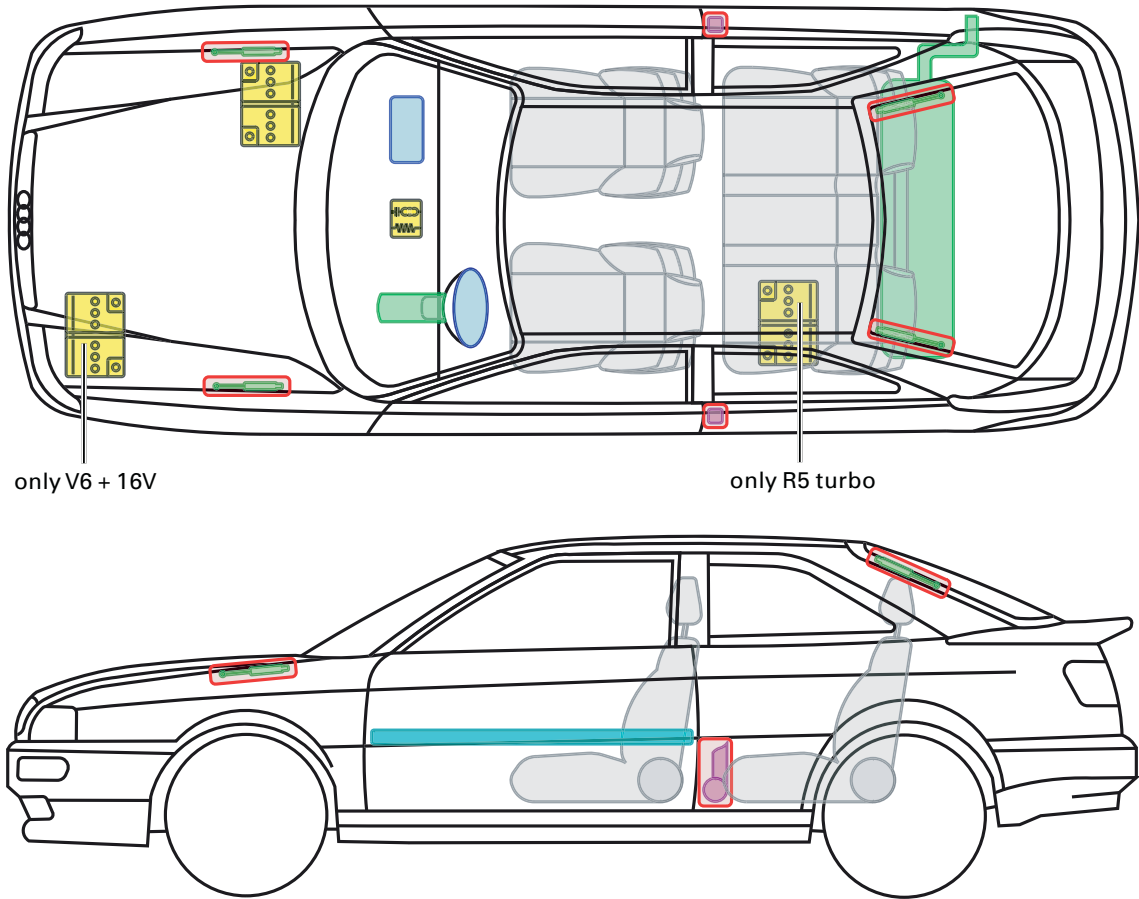

▶ Audi 80 / S2 Coupé

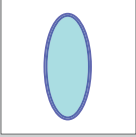
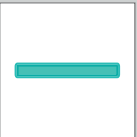
1988 – 1996

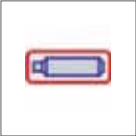

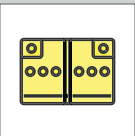
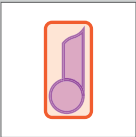
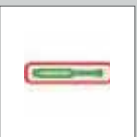
Legend

	Airbag		Reinforce-ment		Control module
	Gas generator		Rollover protection		Battery
	Pre-tensioner		Gas-pressure damper		Fuel tank

This document is a subject to the copyright of AUDI AG, Ingolstadt. Any duplication, distribution, storage, communication, broadcast and reproduction or transmission of the contents without written approval from AUDI AG is prohibited.







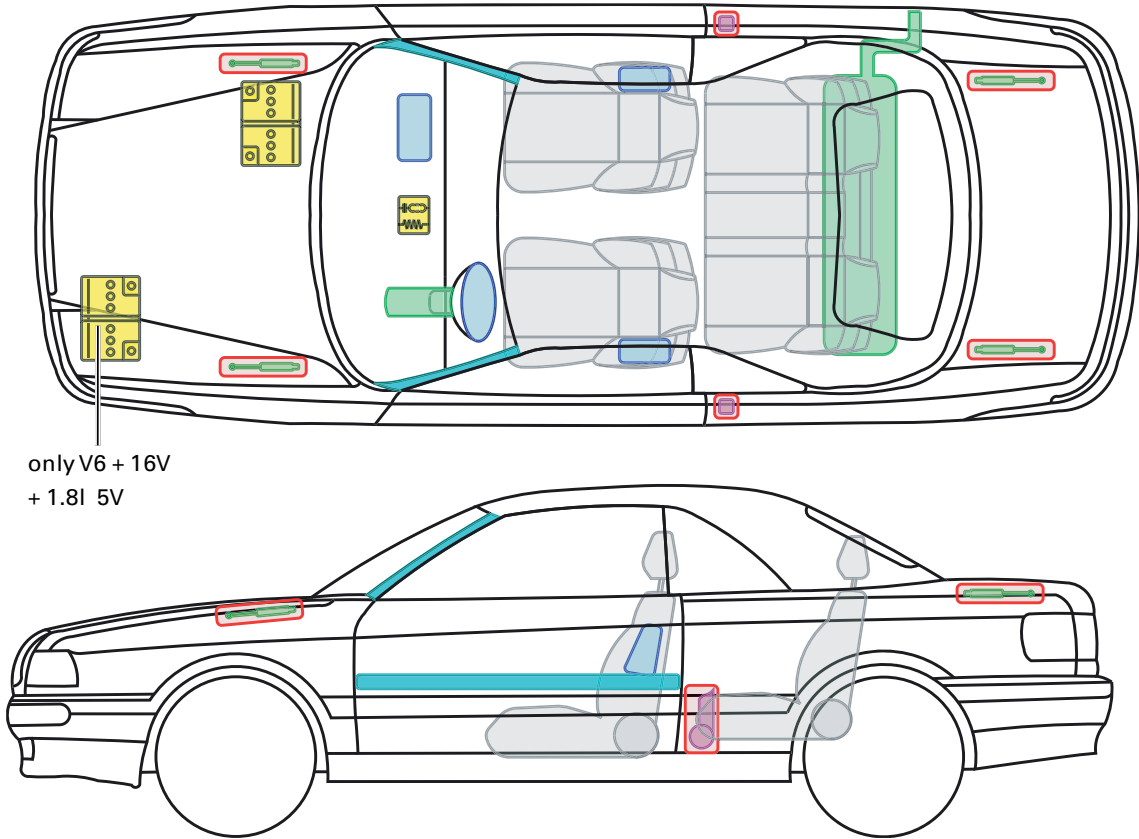

▶ Audi 80 Cabriolet

1991 – 2000

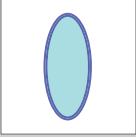

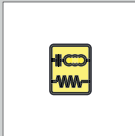
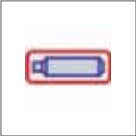
only V6 + 16V
+ 1.8l 5V

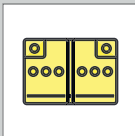
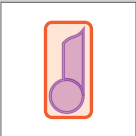
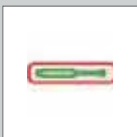
Legend

	Airbag		Reinforce-ment		Control module
	Gas generator		Rollover protection		Battery
	Pre-tensioner		Gas-pressure damper		Fuel tank

This document is a subject to the copyright of AUDI AG, Ingolstadt. Any duplication, distribution, storage, communication, broadcast and reproduction or transmission of the contents without written approval from AUDI AG is prohibited.



Audi 100

1988 – 1991

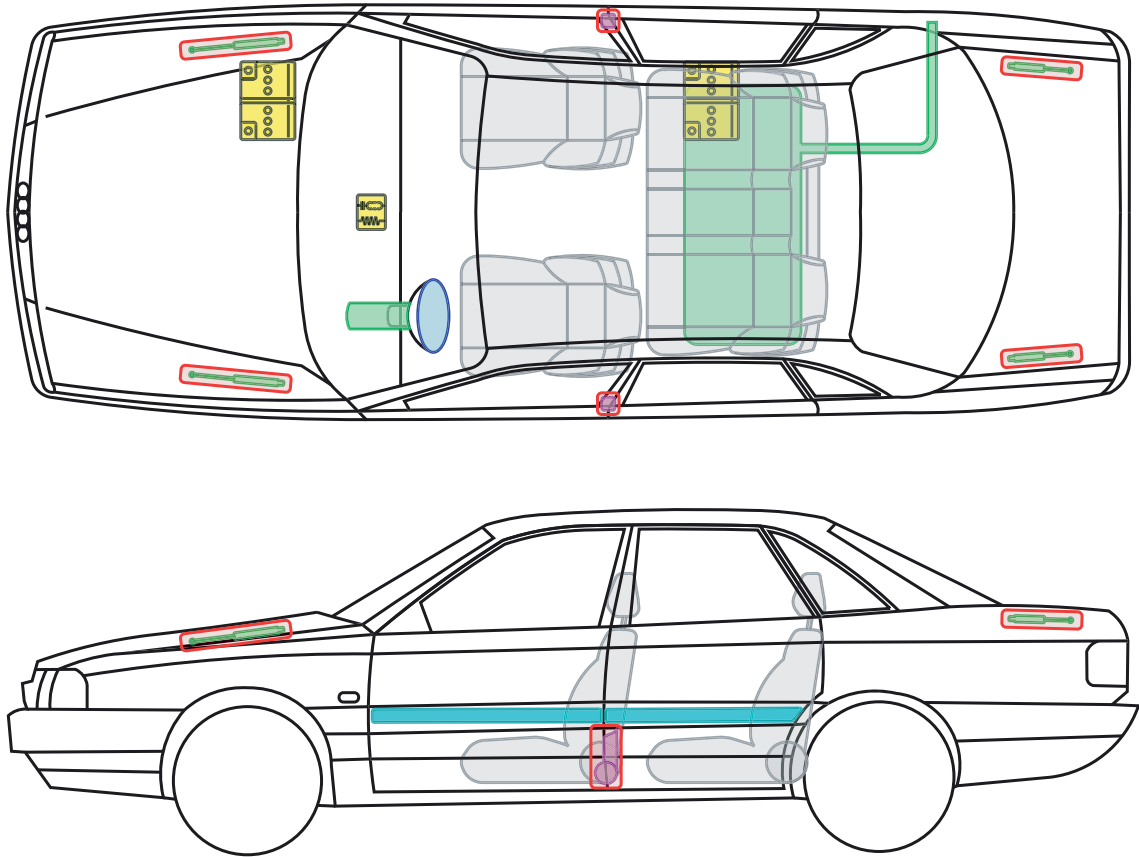

Legend

	Airbag		Reinforcement		Control module
	Gas generator		Rollover protection		Battery
	Pre-tensioner		Gas-pressure damper		Fuel tank

This document is a subject to the copyright of AUDI AG, Ingolstadt. Any duplication, distribution, storage, communication, broadcast and reproduction or transmission of the contents without written approval from AUDI AG is prohibited.







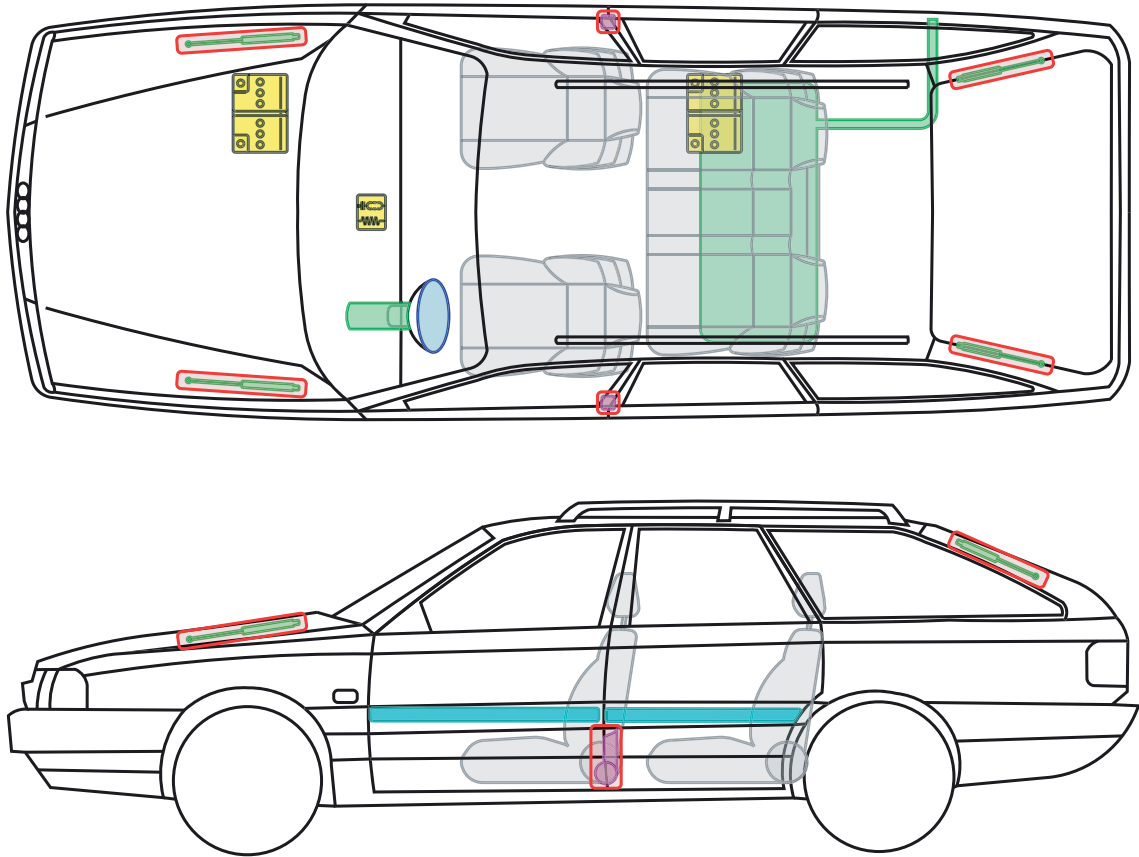

▶ Audi 100 Avant

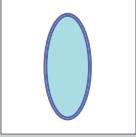
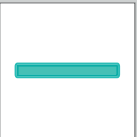
1988 – 1991

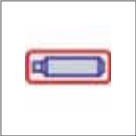

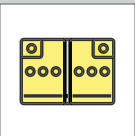
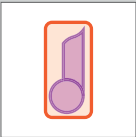
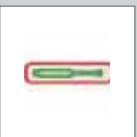
Legend

	Airbag		Reinforcement		Control module
	Gas generator		Rollover protection		Battery
	Pre-tensioner		Gas-pressure damper		Fuel tank

This document is a subject to the copyright of AUDI AG, Ingolstadt. Any duplication, distribution, storage, communication, broadcast and reproduction or transmission of the contents without written approval from AUDI AG is prohibited.



▶ Audi 100 / A6 / S6

1991 – 1997

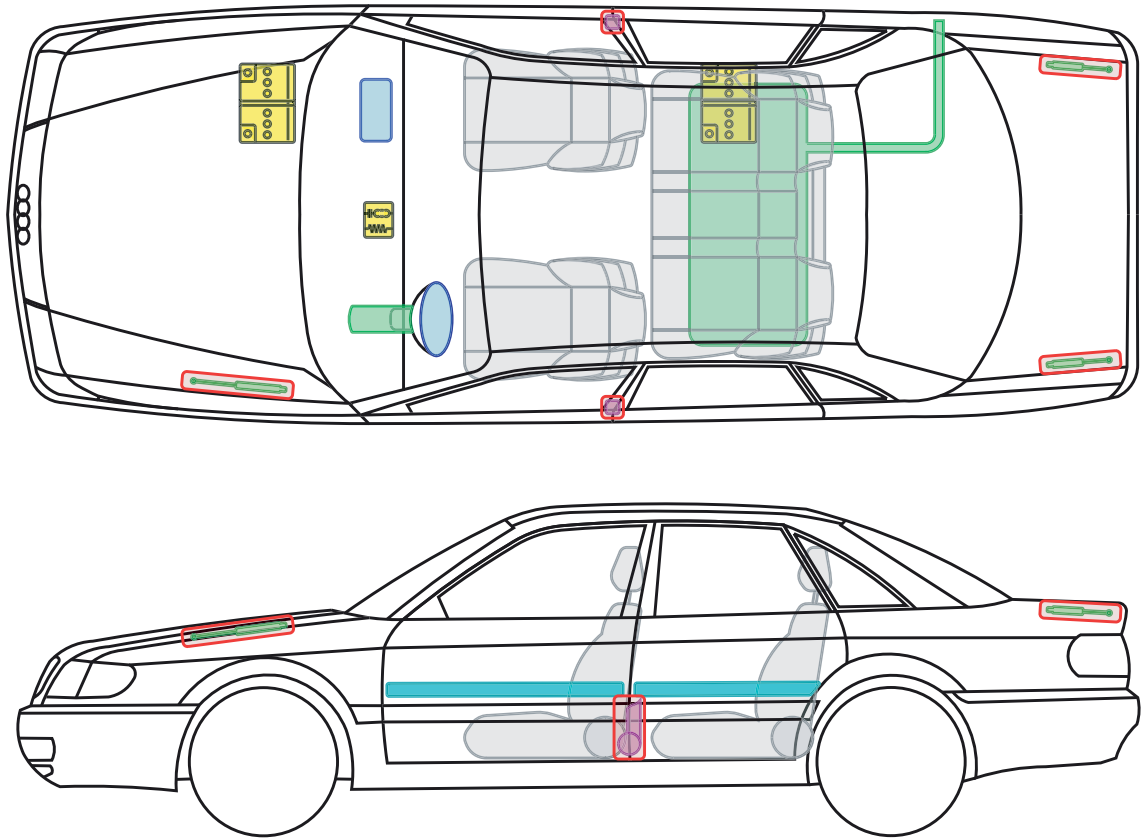

Legend

	Airbag		Reinforcement		Control module
	Gas generator		Rollover protection		Battery
	Pretensioner		Gas-pressure damper		Fuel tank





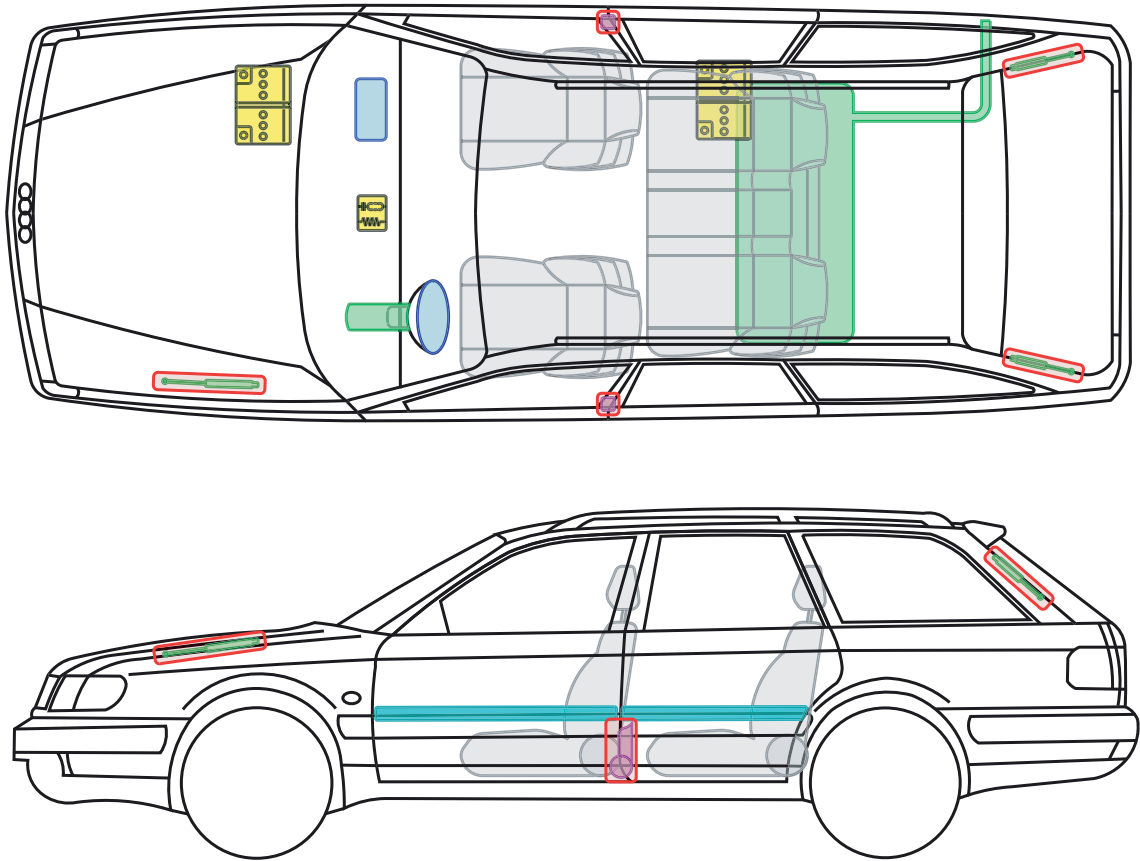

This document is a subject to the copyright of AUDI AG, Ingolstadt. Any duplication, distribution, storage, communication, broadcast and reproduction or transmission of the contents without written approval from AUDI AG is prohibited.

Audi 100 / A6 / S6 Avant

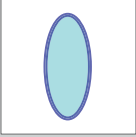
1991 – 1997

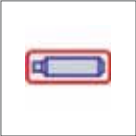

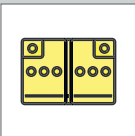
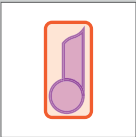
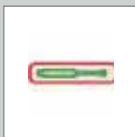
Legend

	Airbag		Reinforcement		Control module
	Gas generator		Rollover protection		Battery
	Pre-tensioner		Gas-pressure damper		Fuel tank

This document is a subject to the copyright of AUDI AG, Ingolstadt. Any duplication, distribution, storage, communication, broadcast and reproduction or transmission of the contents without written approval from AUDI AG is prohibited.







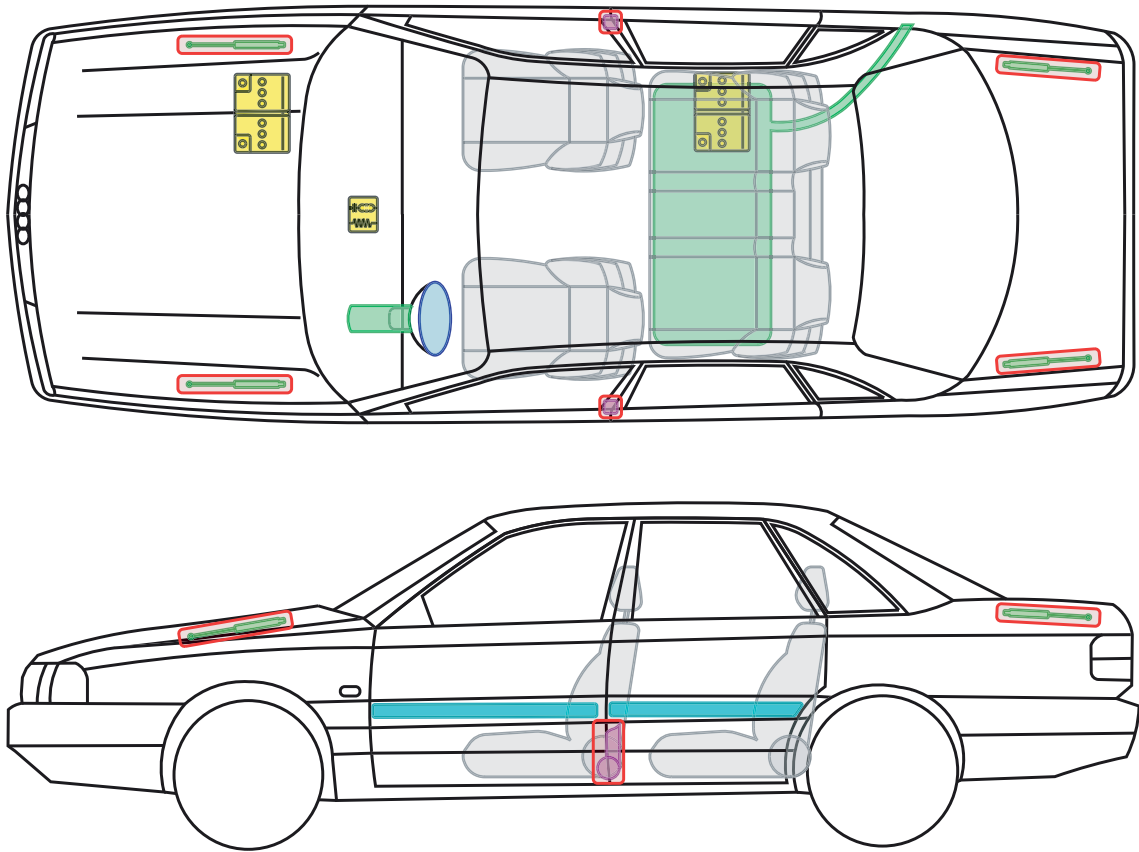

▶ Audi 200 / V8

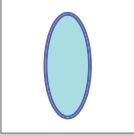
1984 – 1991

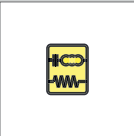
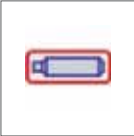

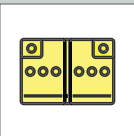
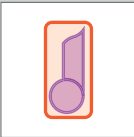
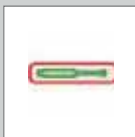
Legend

	Airbag		Reinforce-ment		Control module
	Gas generator		Rollover protection		Battery
	Pre-tensioner		Gas-pressure damper		Fuel tank

This document is a subject to the copyright of AUDI AG, Ingolstadt. Any duplication, distribution, storage, communication, broadcast and reproduction or transmission of the contents without written approval from AUDI AG is prohibited.





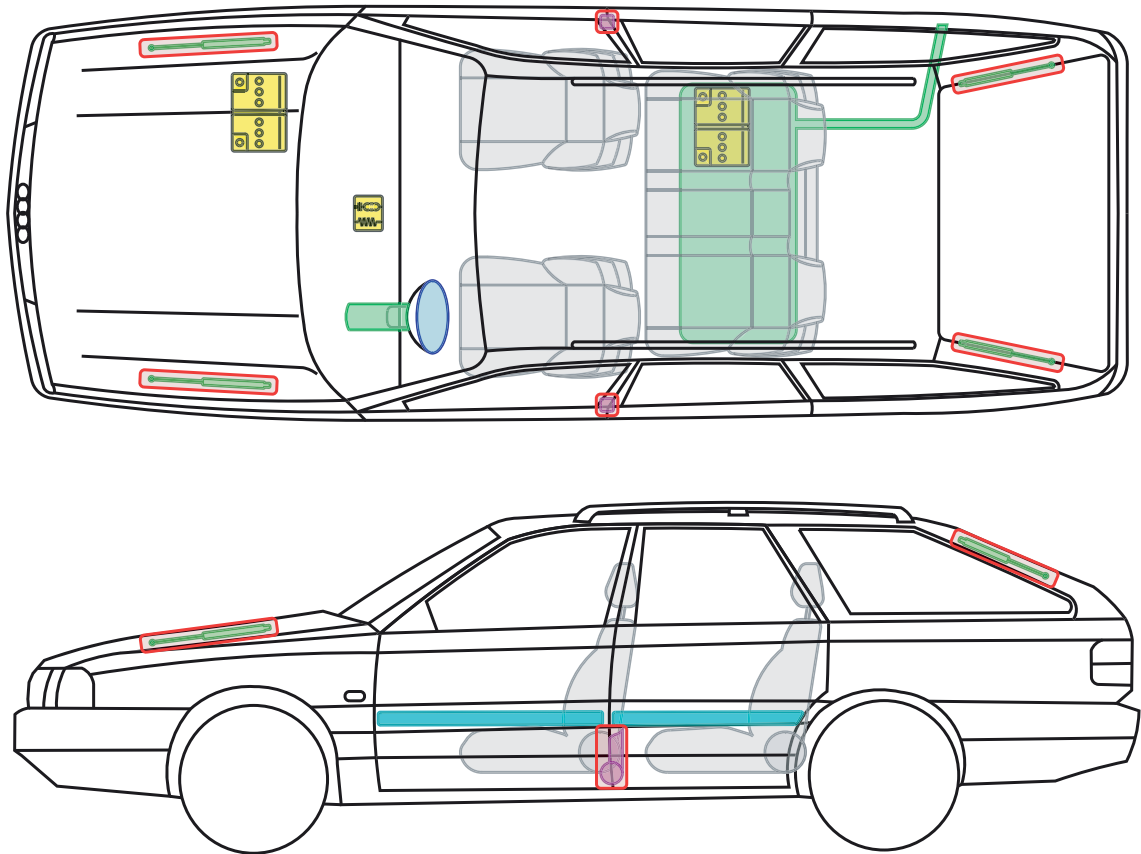

▶ Audi 200 Avant

1985 – 1991

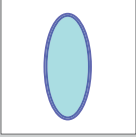
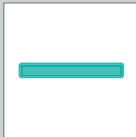
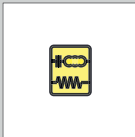
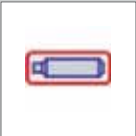

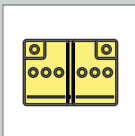
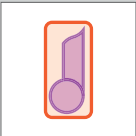
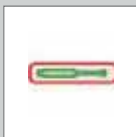
Legend

	Airbag		Reinforcement		Control module
	Gas generator		Rollover protection		Battery
	Pre-tensioner		Gas-pressure damper		Fuel tank

This document is a subject to the copyright of AUDI AG, Ingolstadt. Any duplication, distribution, storage, communication, broadcast and reproduction or transmission of the contents without written approval from AUDI AG is prohibited.







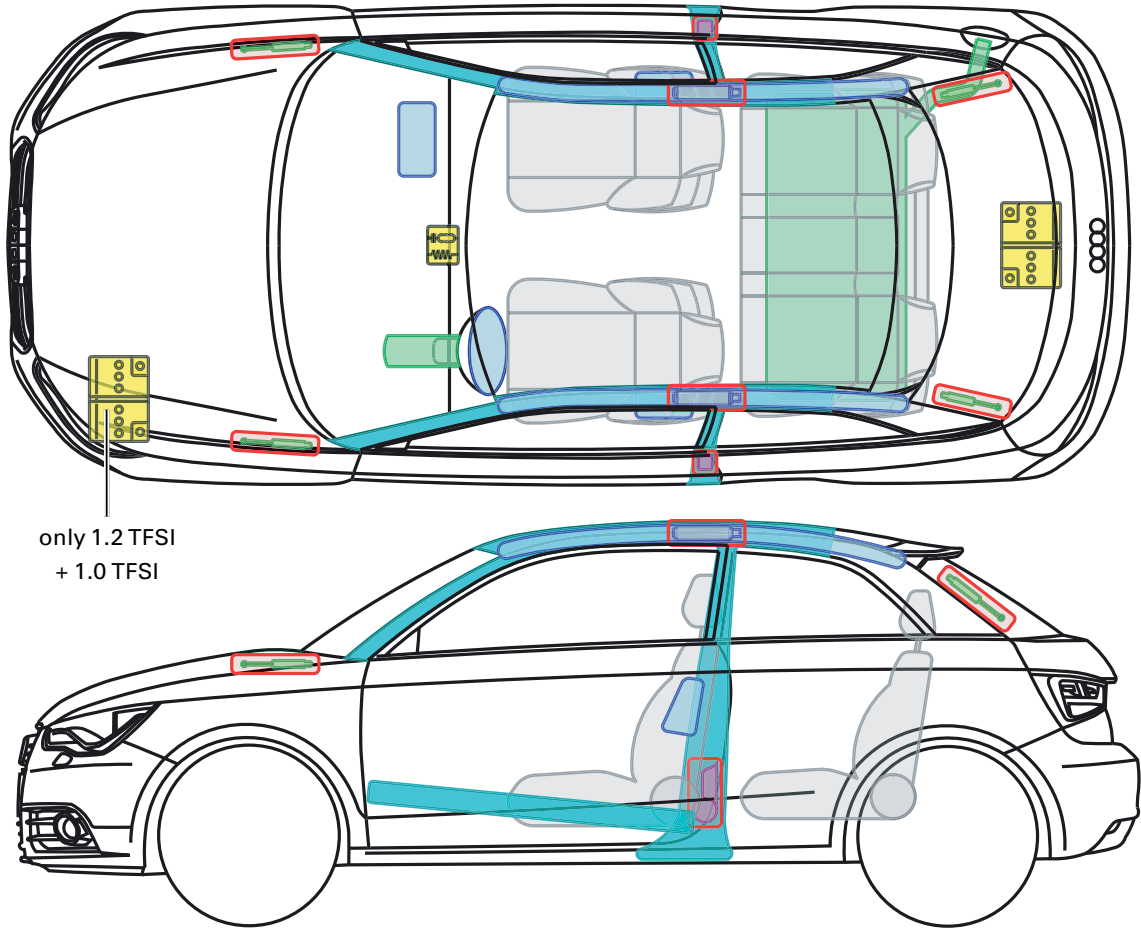

▶ Audi A1 / S1

from 2010

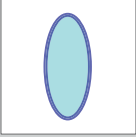

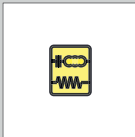
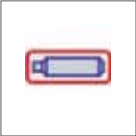
only 1.2 TFSI
+ 1.0 TFSI

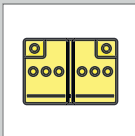
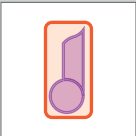
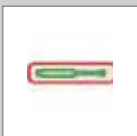
Legend

	Airbag		Reinforce-ment		Control module
	Gas generator		Rollover protection		Battery
	Pre-tensioner		Gas-pressure damper		Fuel tank

This document is a subject to the copyright of AUDI AG, Ingolstadt. Any duplication, distribution, storage, communication, broadcast and reproduction or transmission of the contents without written approval from AUDI AG is prohibited.







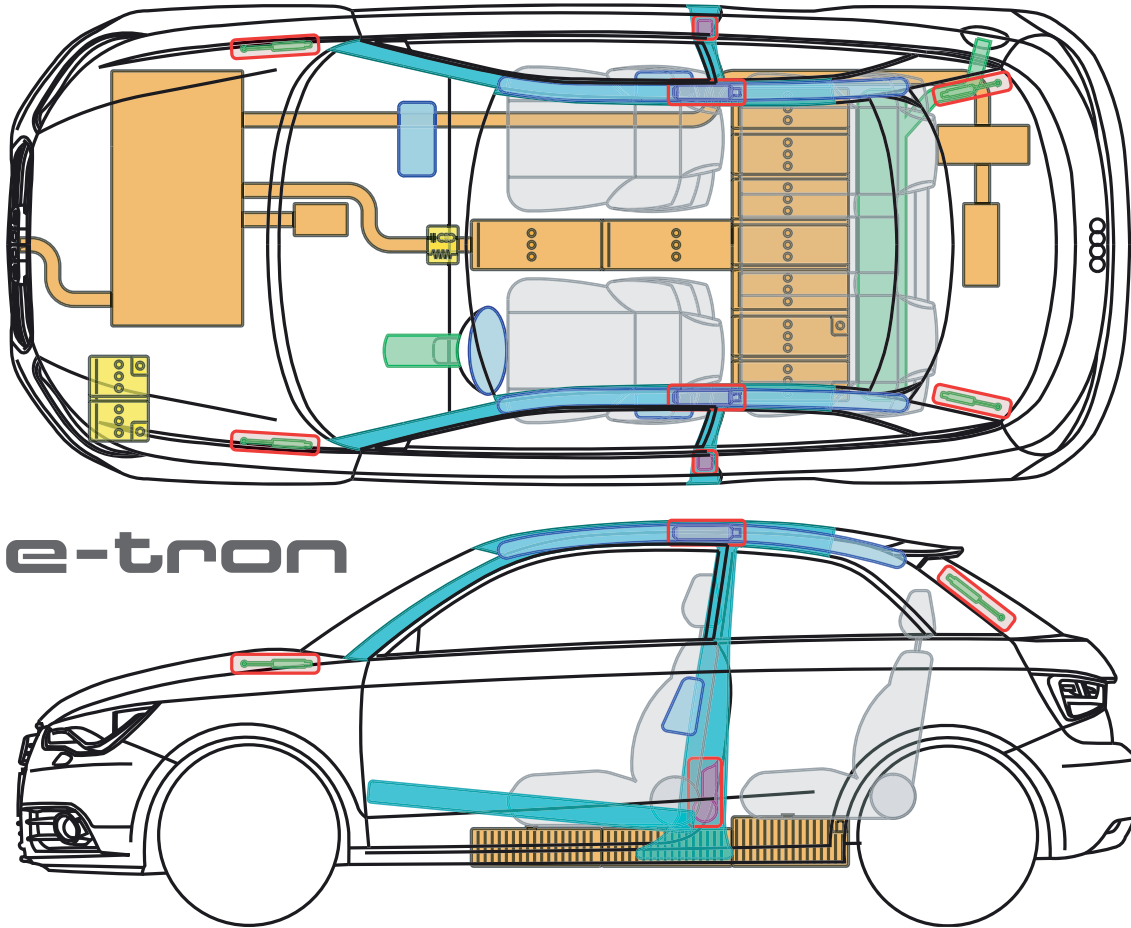

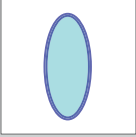

▶ Audi A1 e-tron

from 2011

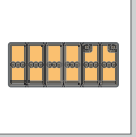
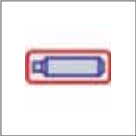

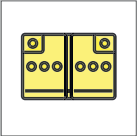
e-tron

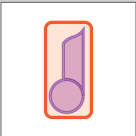
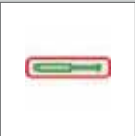
Legend

	Airbag		Reinforcement		Control module		High-voltage battery
	Gas generator		Rollover protection		12 V battery		High-voltage leads/components
	Pretensioner		Gas-pressure damper		Fuel tank		

This document is a subject to the copyright of AUDI AG, Ingolstadt. Any duplication, distribution, storage, communication, broadcast and reproduction or transmission of the contents without written approval from AUDI AG is prohibited.



▶ Audi A1 e-tron

from 2011

Identifying feature

The Audi A1 e-tron can be identified by means of the „e-tron“ logo on the instrument cluster or on the wing.



Instrument cluster



Wing

Hints

⚠ In the case of accidents in which the airbags are deployed, the high-voltage system is deactivated. If the vehicle is connected to the charging point / socket, the charging cable is to be disconnected.

In the case of accidents with deployed / undeployed airbags

- ▶ Place Vehicle in Park and set parking brake
- ▶ Switch off the ignition
- ▶ Disconnect the negative terminal of the 12V battery

⚠ The electric motor is silent!



It may not be possible to detect that the car is ready to go by the noises it makes when in operation, as the electric motor is silent. If the large needle in the dial on the left of the instrument cluster (power metre) is not on „OFF“ (for example on the „READY“ position), you have to expect that the electric motor may run or the internal combustion engine may start automatically.

Identification of the high-voltage components

Identification of the high-voltage battery



Identification of the high-voltage battery is located underneath the vehicle, below the transmission tunnel and the rear seat.

It is a lithium-ion battery.

Identification of the remaining high-voltage components



All the high-voltage leads and the high-voltage connections are provided with orange insulation. These items must not be disconnected or damaged.







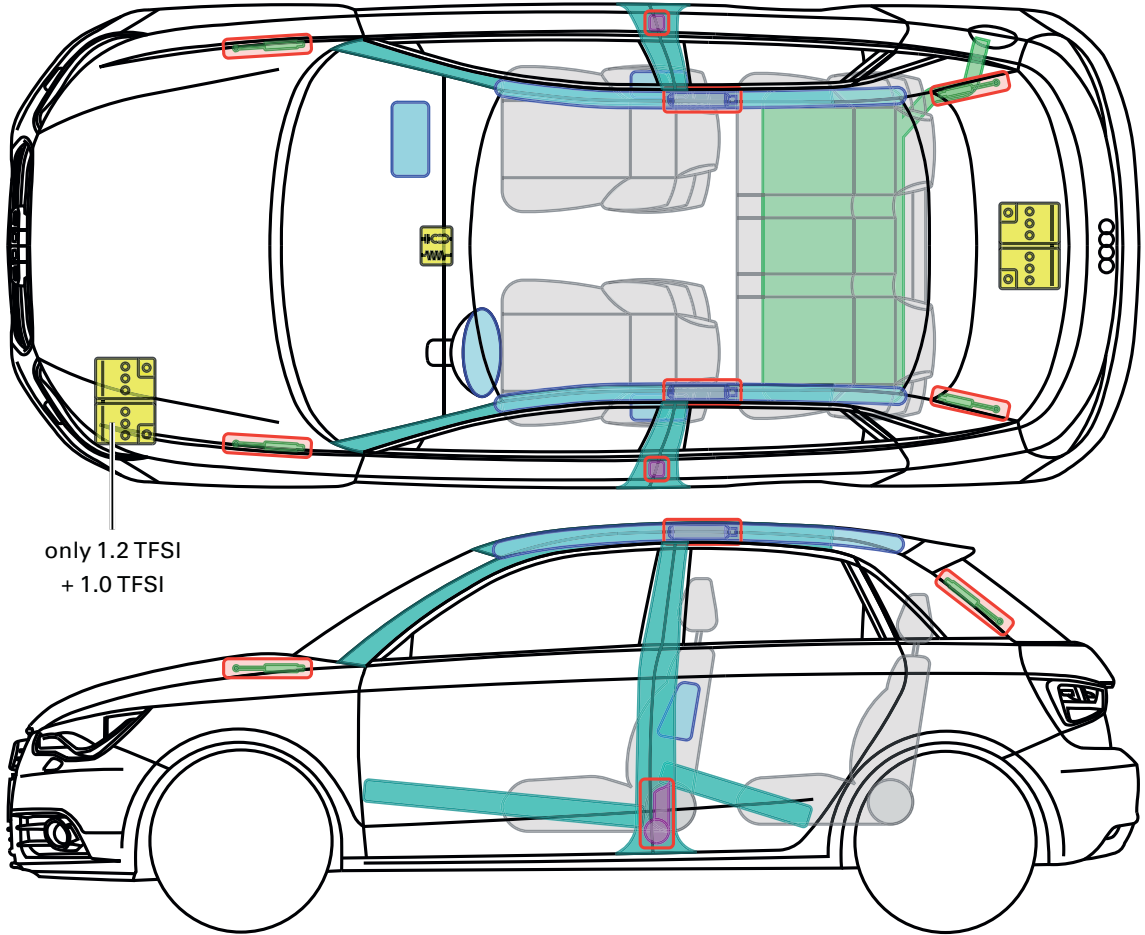

▶ Audi A1 / S1 Sportback

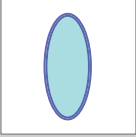
from 2012

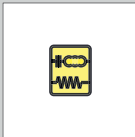
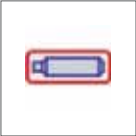

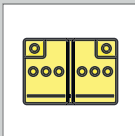
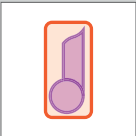
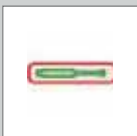
Legend

	Airbag		Reinforcement		Control module
	Gas generator		Rollover protection		Battery
	Pre-tensioner		Gas-pressure damper		Fuel tank

This document is a subject to the copyright of AUDI AG, Ingolstadt. Any duplication, distribution, storage, communication, broadcast and reproduction or transmission of the contents without written approval from AUDI AG is prohibited.







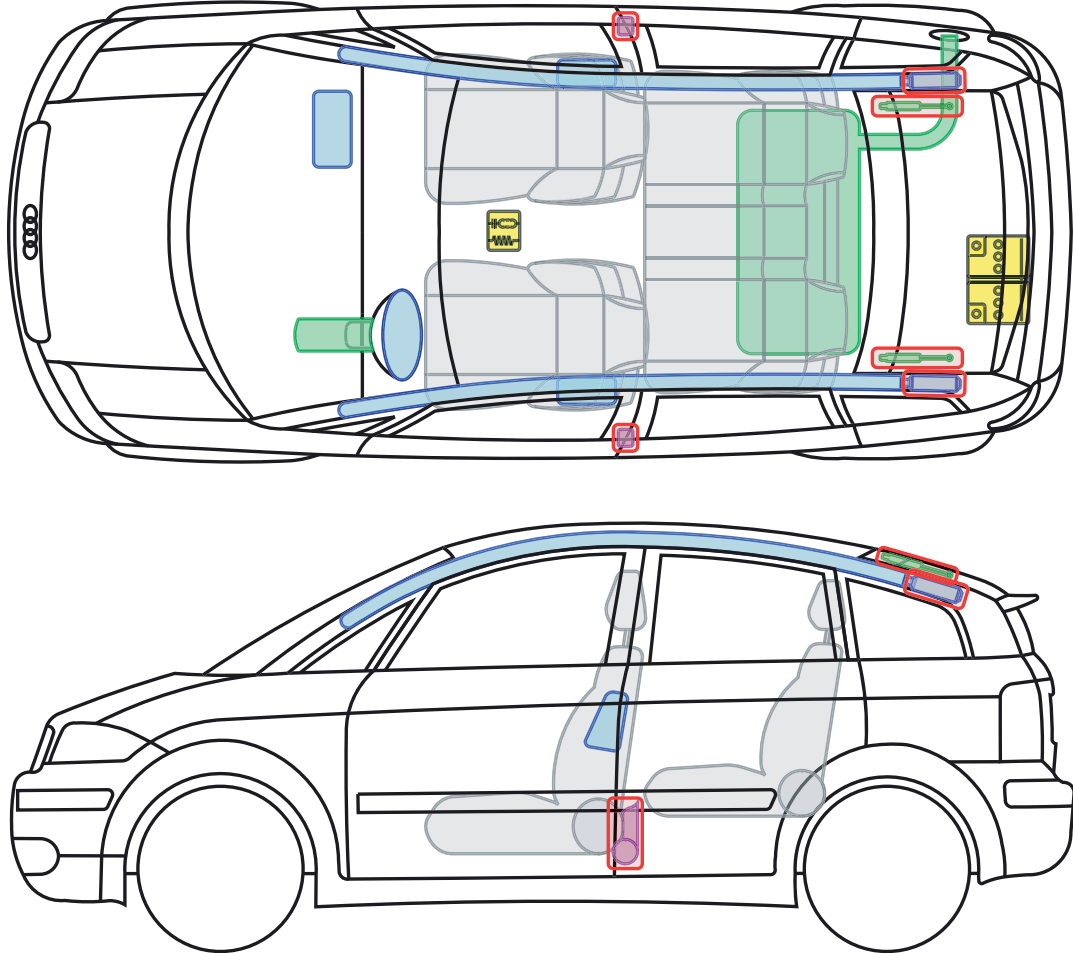

Audi A2

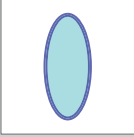
2000 – 2005

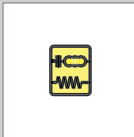
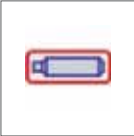

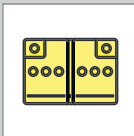
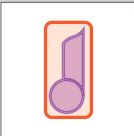
Legend

	Airbag		Reinforcement		Control module
	Gas generator		Rollover protection		Battery
	Pre-tensioner		Gas-pressure damper		Fuel tank

This document is a subject to the copyright of AUDI AG, Ingolstadt. Any duplication, distribution, storage, communication, broadcast and reproduction or transmission of the contents without written approval from AUDI AG is prohibited.







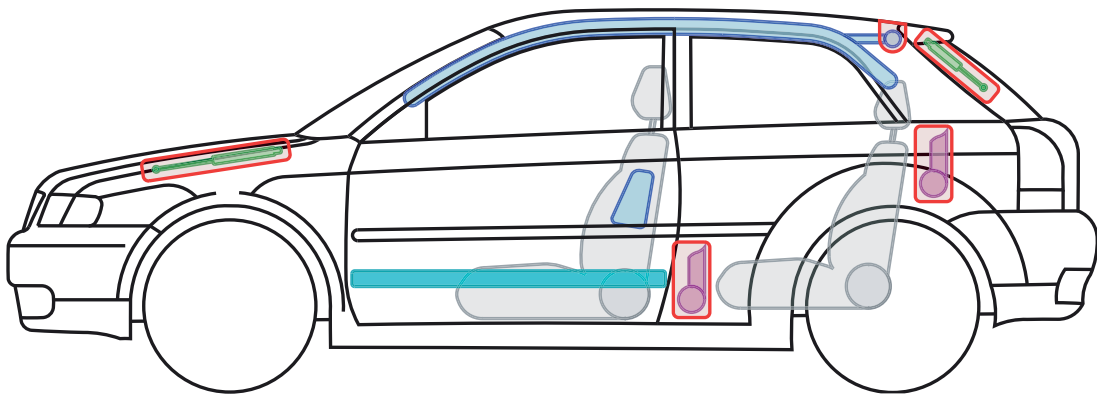
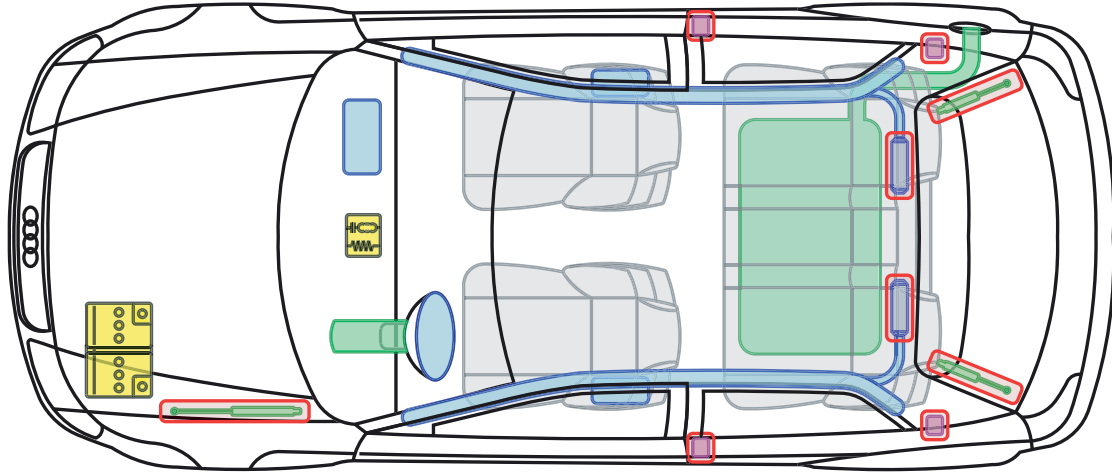

▶ Audi A3 / S3 (3-door)

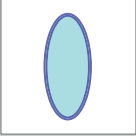
1996 – 2003

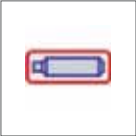

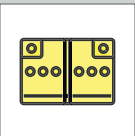
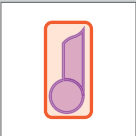
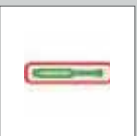
Legend

	Airbag		Reinforcement		Control module
	Gas generator		Rollover protection		Battery
	Pre-tensioner		Gas-pressure damper		Fuel tank

This document is a subject to the copyright of AUDI AG, Ingolstadt. Any duplication, distribution, storage, communication, broadcast and reproduction or transmission of the contents without written approval from AUDI AG is prohibited.







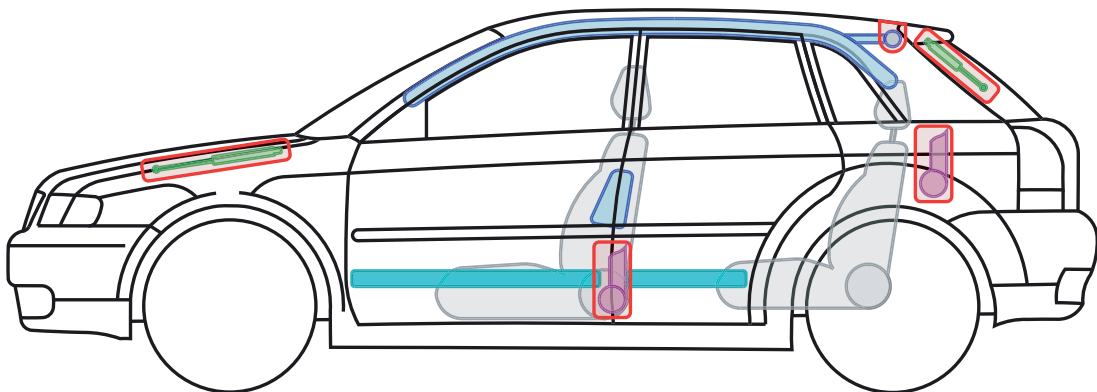
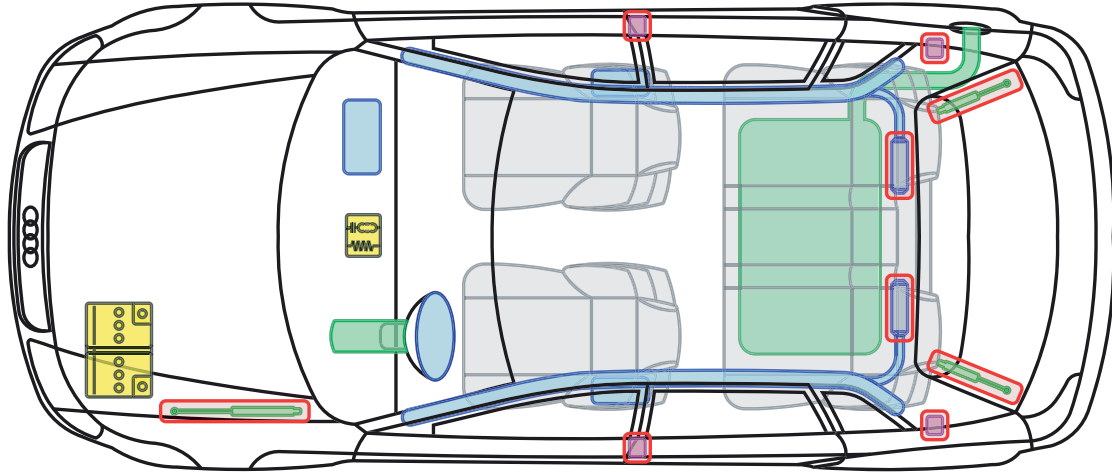

▶ Audi A3 (5-door)

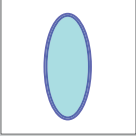
1999 – 2003

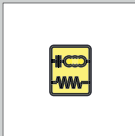
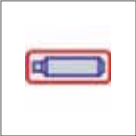

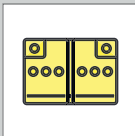
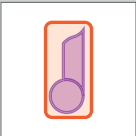
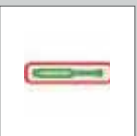
Legend

	Airbag		Reinforcement		Control module
	Gas generator		Rollover protection		Battery
	Pretensioner		Gas-pressure damper		Fuel tank

This document is a subject to the copyright of AUDI AG, Ingolstadt. Any duplication, distribution, storage, communication, broadcast and reproduction or transmission of the contents without written approval from AUDI AG is prohibited.





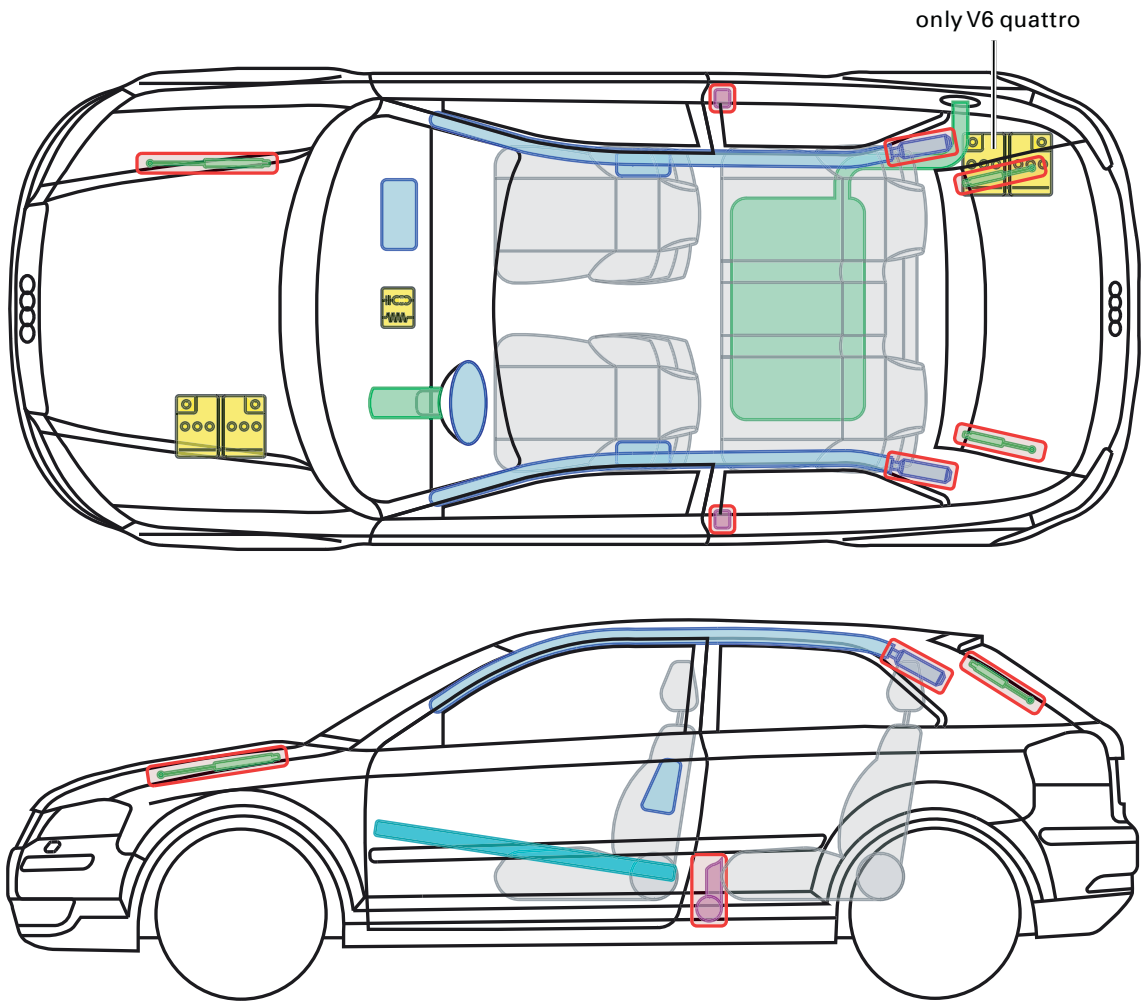

▶ Audi A3 / S3 (3-door)

2003 – 2012

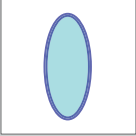
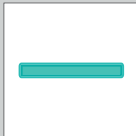
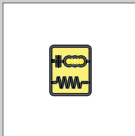
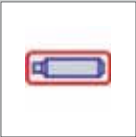

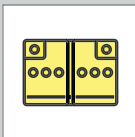
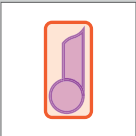
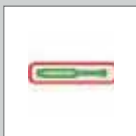
Legend

	Airbag		Reinforcement		Control module
	Gas generator		Rollover protection		Battery
	Pretensioner		Gas-pressure damper		Fuel tank

This document is a subject to the copyright of AUDI AG, Ingolstadt. Any duplication, distribution, storage, communication, broadcast and reproduction or transmission of the contents without written approval from AUDI AG is prohibited.



▶ Audi A3 / S3 / RS3 Sportback

2004 – 2012

only V6 quattro + RS3

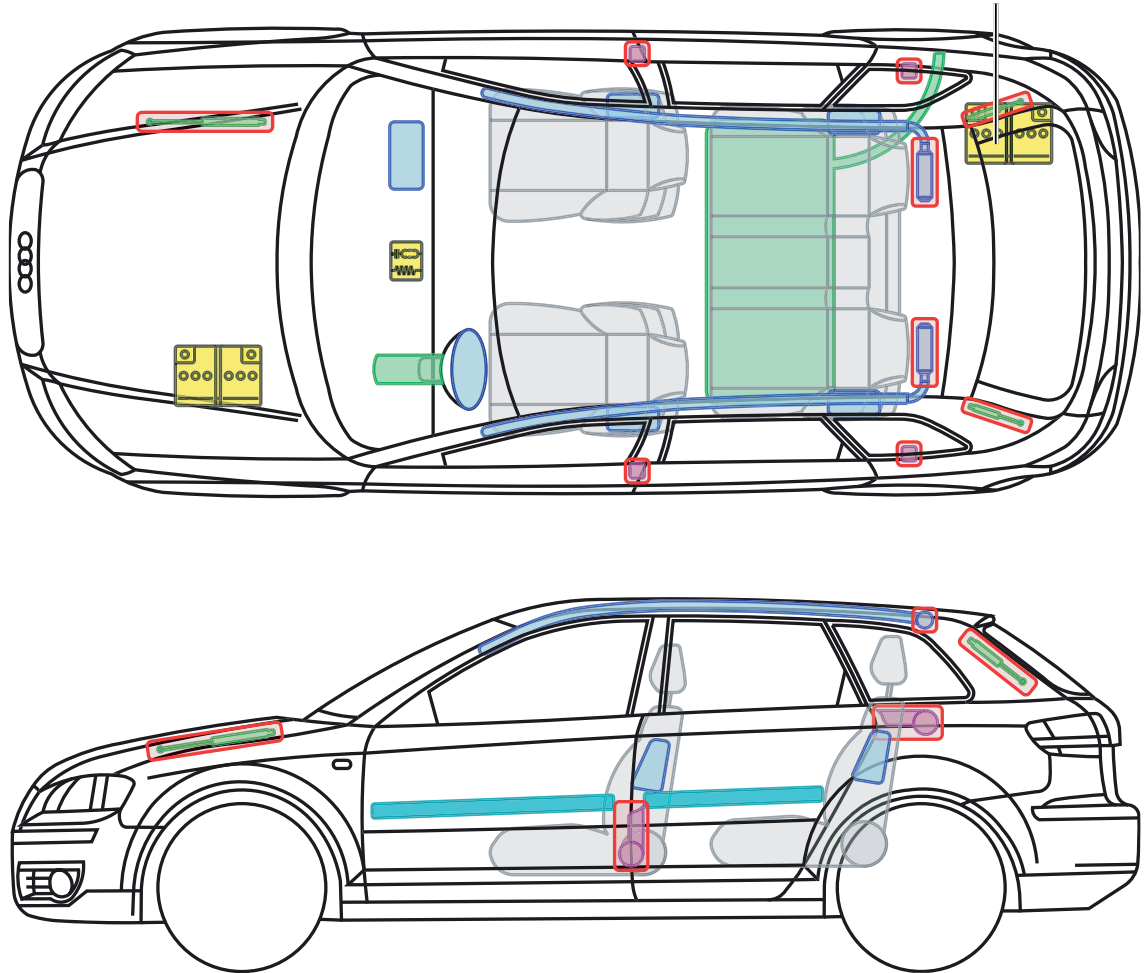

Legend

	Airbag		Reinforcement		Control module
	Gas generator		Rollover protection		Battery
	Pre-tensioner		Gas-pressure damper		Fuel tank

This document is a subject to the copyright of AUDI AG, Ingolstadt. Any duplication, distribution, storage, communication, broadcast and reproduction or transmission of the contents without written approval from AUDI AG is prohibited.





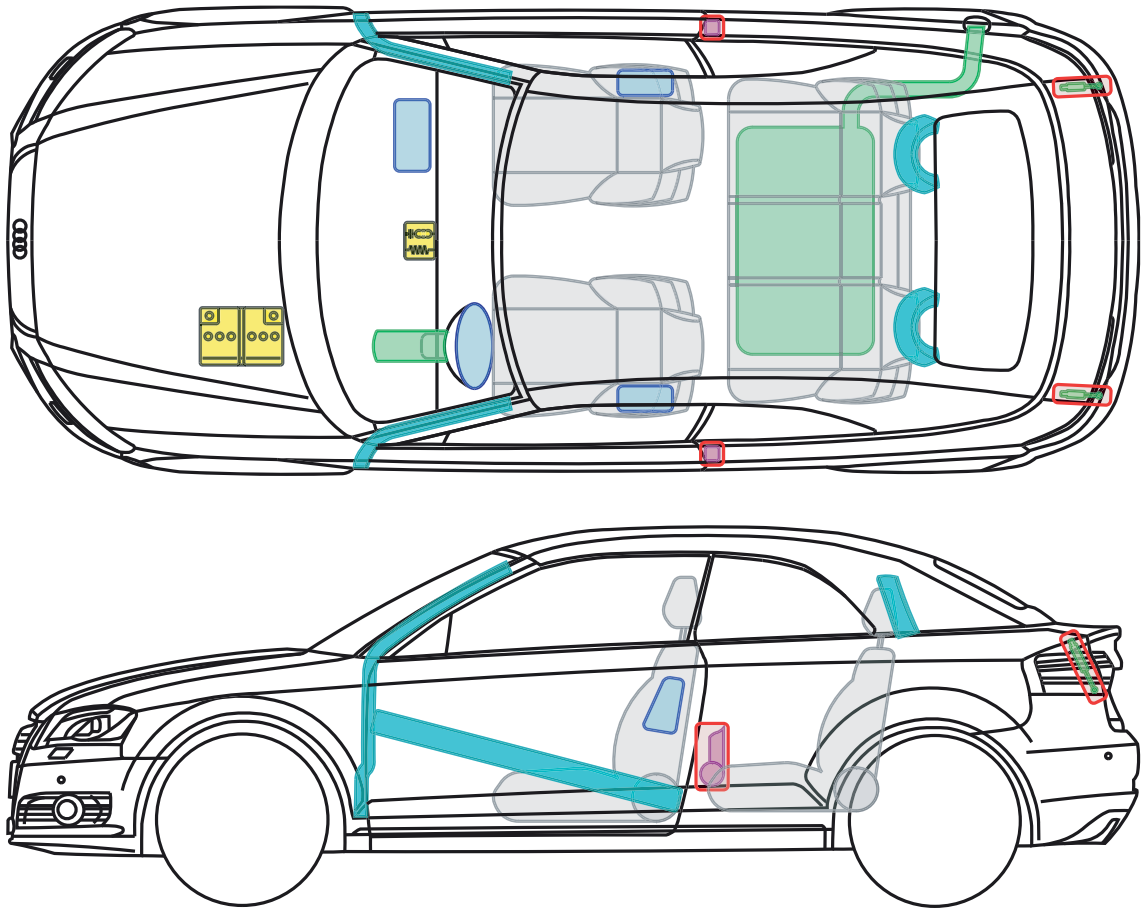

▶ Audi A3 Cabriolet

2008 – 2013

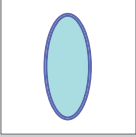
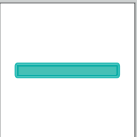
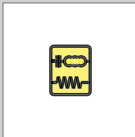
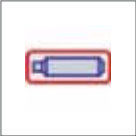

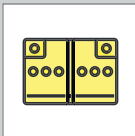
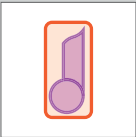
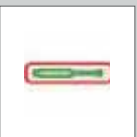
Legend

	Airbag		Reinforcement		Control module
	Gas generator		Rollover protection		Battery
	Pre-tensioner		Gas-pressure damper		Fuel tank

This document is a subject to the copyright of AUDI AG, Ingolstadt. Any duplication, distribution, storage, communication, broadcast and reproduction or transmission of the contents without written approval from AUDI AG is prohibited.







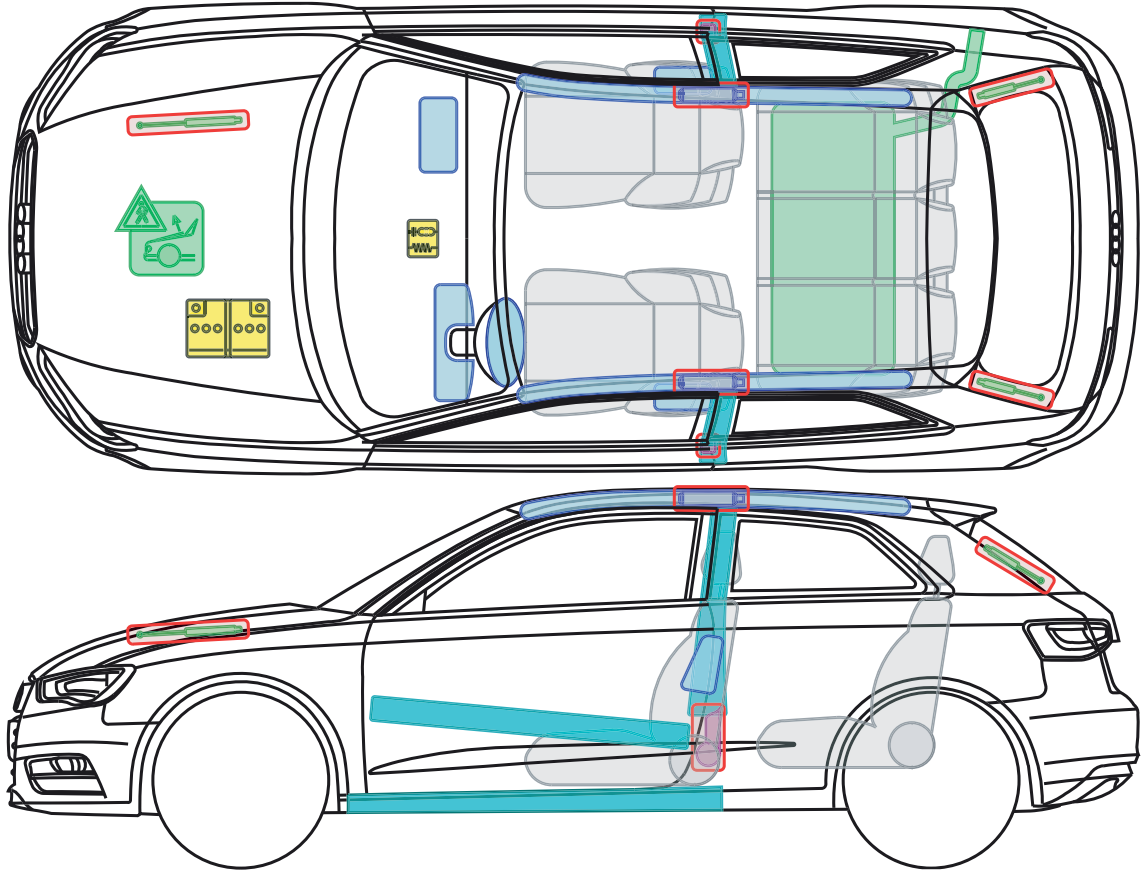

▶ Audi A3 / S3 (3-door)

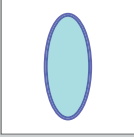
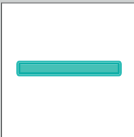
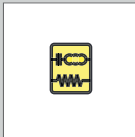
from 2012

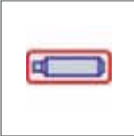

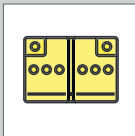
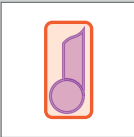
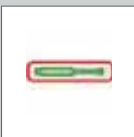
Legend

	Airbag		Reinforcement		Control module		Pedestrian protection system
	Gas generator		Overroll protection		12 V battery		
	Pretensioner		Gas-pressure damper		Fuel tank		

This document is a subject to the copyright of AUDI AG, Ingolstadt. Any duplication, distribution, storage, communication, broadcast and reproduction or transmission of the contents without written approval from AUDI AG is prohibited.







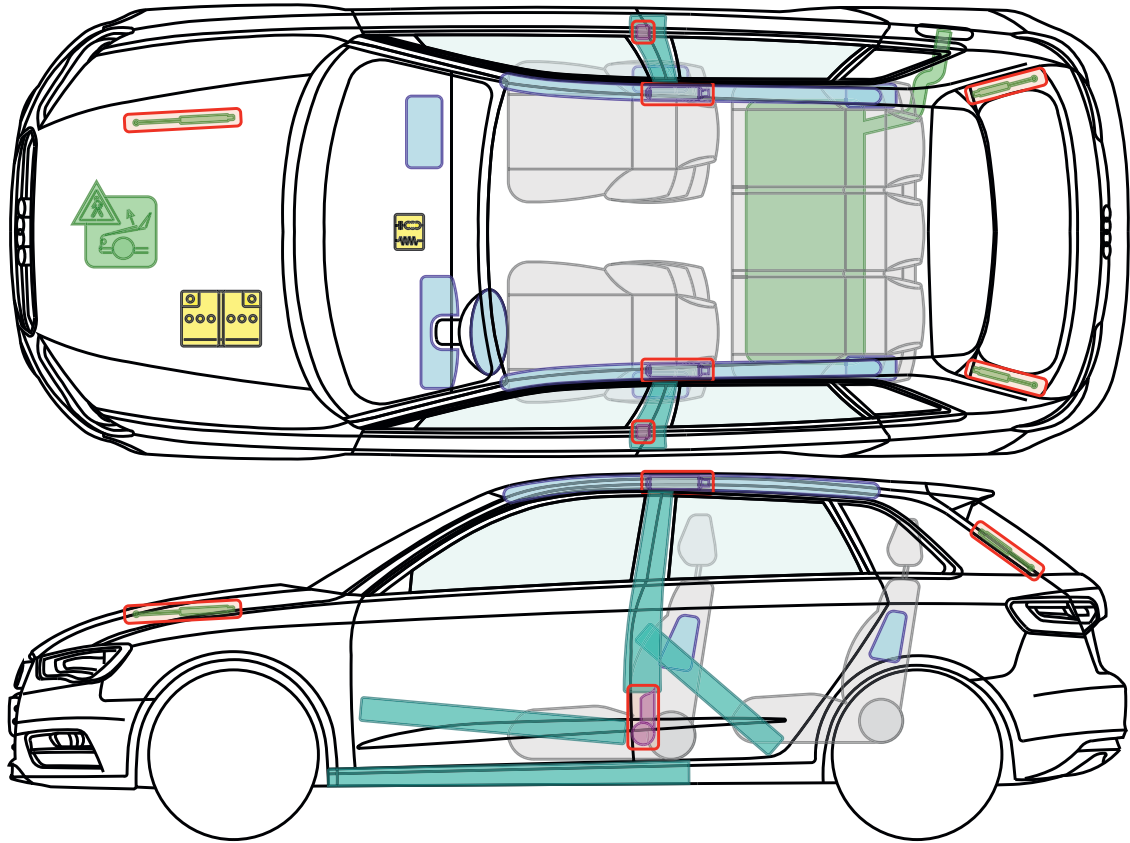

▶ Audi A3 / S3 Sportback

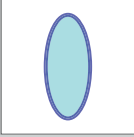
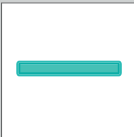
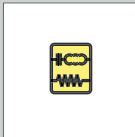
from 2012

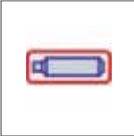

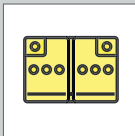
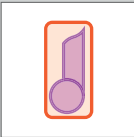
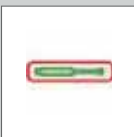
Legend

	Airbag		Reinforcement		Control module		Pedestrian protection system
	Gas generator		Overroll protection		12 V battery		
	Pretensioner		Gas-pressure damper		Fuel tank		

This document is a subject to the copyright of AUDI AG, Ingolstadt. Any duplication, distribution, storage, communication, broadcast and reproduction or transmission of the contents without written approval from AUDI AG is prohibited.







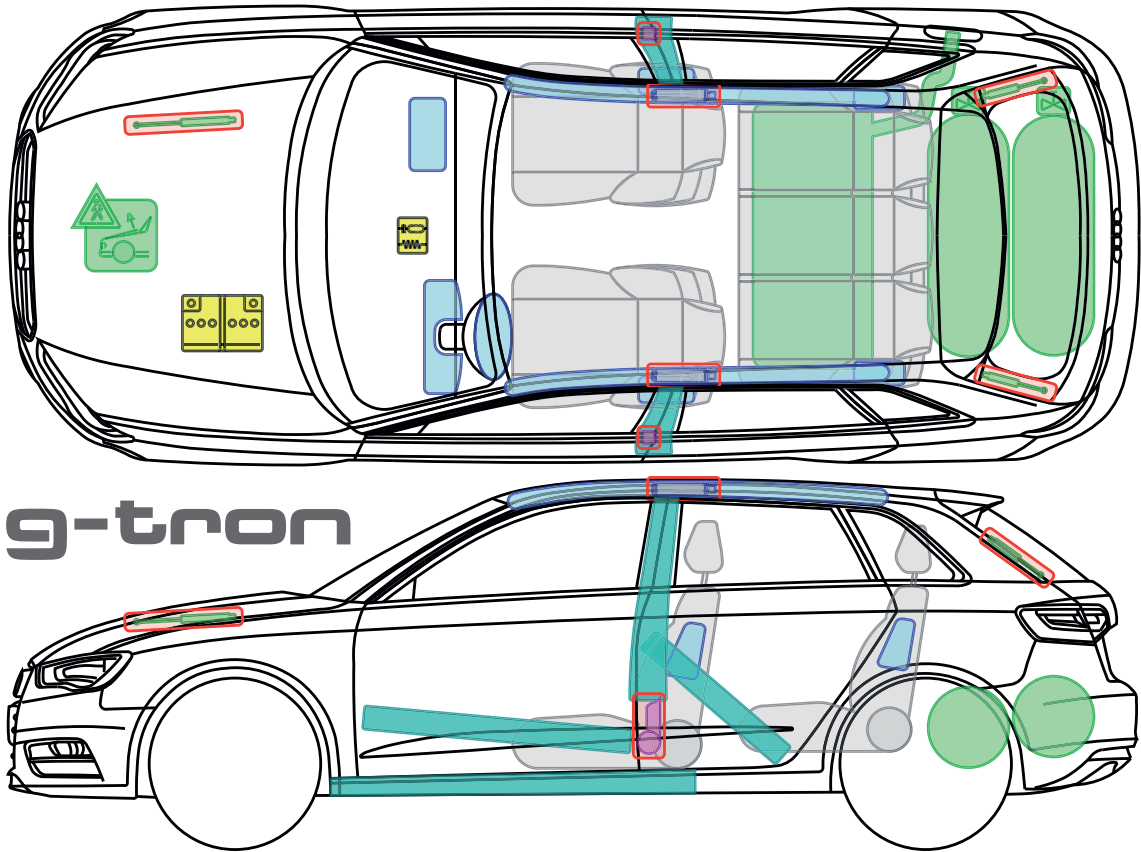

▶ Audi A3 Sportback g-tron

from 2013

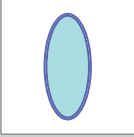
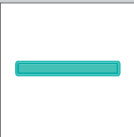
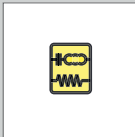
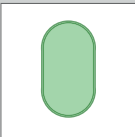
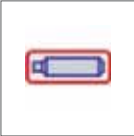

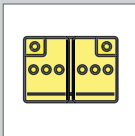
g-tron

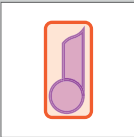
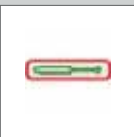
Legend

	Airbag		Reinforcement		Control module		Gas tank
	Gas generator		Overroll protection		12 V battery		Safety valve
	Pretensioner		Gas-pressure damper		Fuel tank		Pedestrian protection system

This document is a subject to the copyright of AUDI AG, Ingolstadt. Any duplication, distribution, storage, communication, broadcast and reproduction or transmission of the contents without written approval from AUDI AG is prohibited.

▶ Audi A3 Sportback g-tron

from 2013

Shut off gas tank manually

(e. g. in the case of smell of gas or leaking natural gas)

1. Access to natural gas tanks



- ▶ Gas tanks are accessible from underbody.
- ▶ Gas tanks are protected by a plastic cover. In order to access the gas tanks, the cover needs to be removed without damaging the components of the gas system located below.

2. Locate safety valves

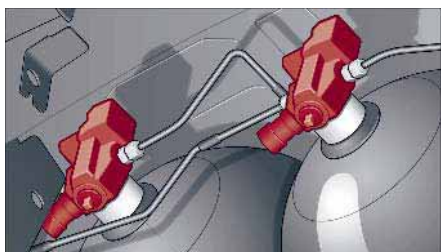

- ▶ Each gas tank is equipped with its individual cylinder valve and manual stopcock.

3. Switch off gas tank manually

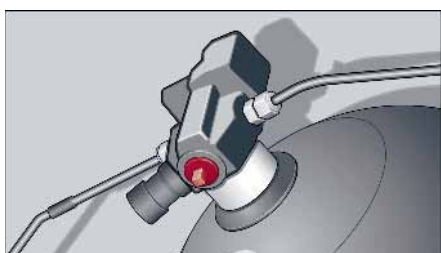

- ▶ If required, each fuel tank must allow separate shut-off.
- ▶ By means of a 5 mm open-end wrench or ring spanner the manual shut-off valve may be shut off by means of turning the square clockwise until reaching the stop of the valve.



▶ Audi A3 Sportback e-tron

from 2014

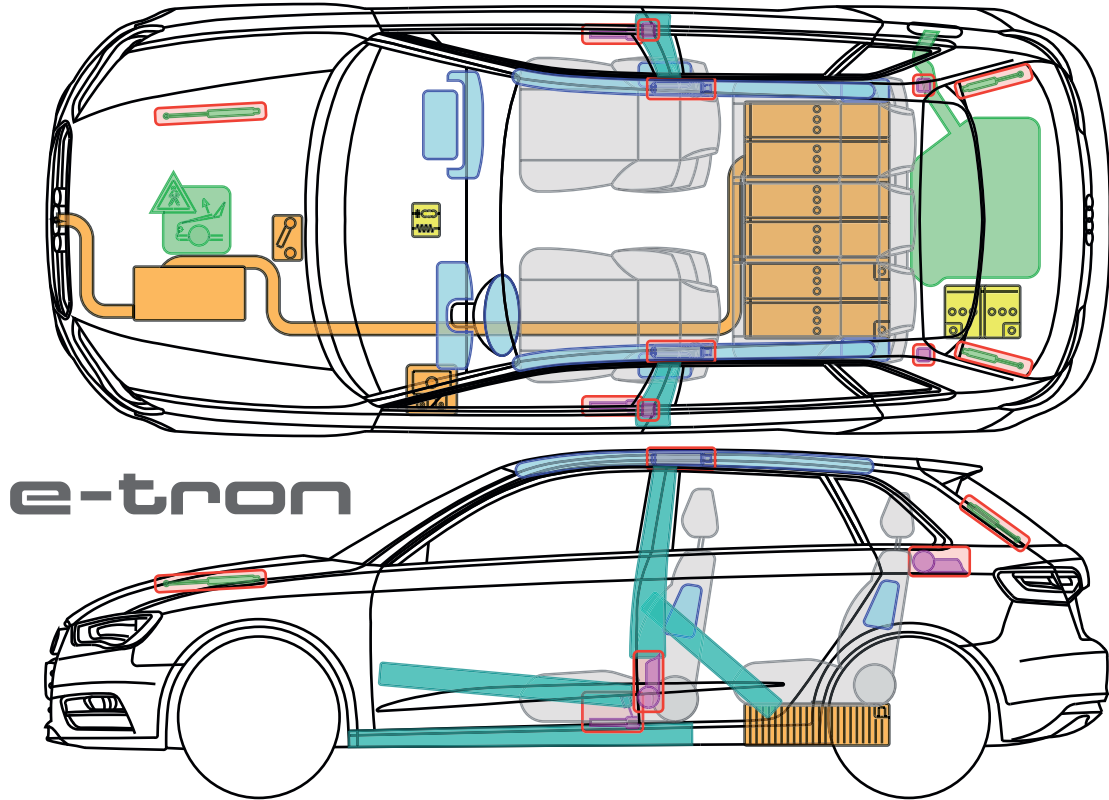

Legend

	Airbag		Overroll protection		Fuel tank		High-voltage emergency disconnect
	Gas generator		Gas-pressure damper		High-voltage battery		Pedestrian protection system
	Pretensioner		Control module		High-voltage -leads/ -components		
	Reinforcement		12 V battery		High-voltage emergency disconnect fuse		

This document is a subject to the copyright of AUDI AG, Ingolstadt. Any duplication, distribution, storage, communication, broadcast and reproduction or transmission of the contents without written approval from AUDI AG is prohibited.

Audi A3 Sportback e-tron

from 2014

Characteristic features

The A3 e-tron can be identified by the e-tron logo, the orange cables (e. g. in engine compartment) and the charging socket.



e-tron

Vehicle immobilization

1. Gear lever in position park „P“
2. Apply parking brake



Switch off ignition

Press START-ENGINE-STOP button **without** depressing brake pedal.



⚠ Warning: When pressing the START-ENGINE-STOP button and depressing the brake pedal at the same time, the engine will start!

Audi A3 Sportback e-tron

from 2014

Deactivation of High Voltage System

Alternative 1 – Engine compartment accessible

1. Localize emergency disconnect
2. Open safety disconnect

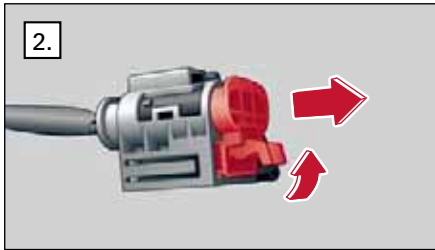
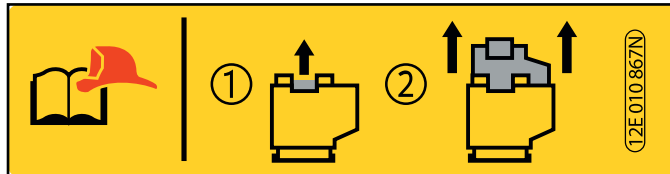
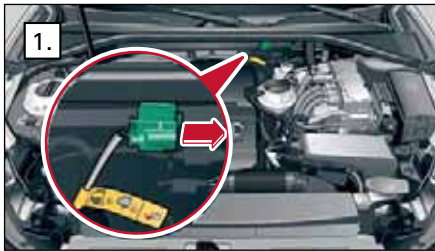

Alternative 2 – Emergency disconnect fuse in passenger compartment

1. Identify emergency fuse
2. Disconnect emergency fuse



Fuse box – **left-hand drive** (steering wheel left)

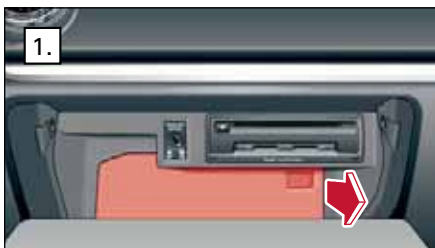

Fuse box in glove compartment
right-hand drive (steering wheel right)

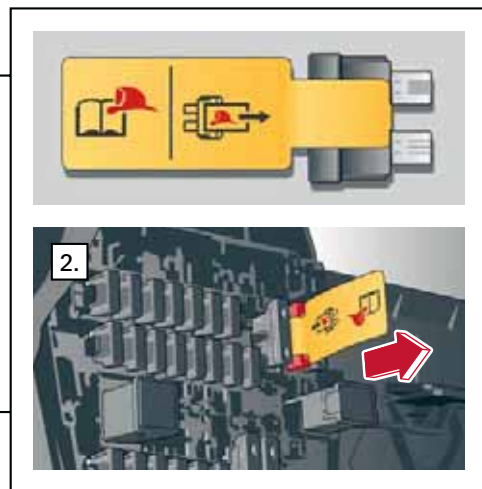

▶ Audi A3 Sportback e-tron

from 2014

Disconnect 12 V battery

The 12 V battery is located in the luggage compartment below the luggage compartment floor. The cables of both terminals are fed out directly through the plastic cover.



Disconnect charging cable

Vehicle connected to charging station:

1. Unlock vehicle via remote control or central locking switch
2. Disconnect charging cable

If required, follow further steps of this rescue data sheet

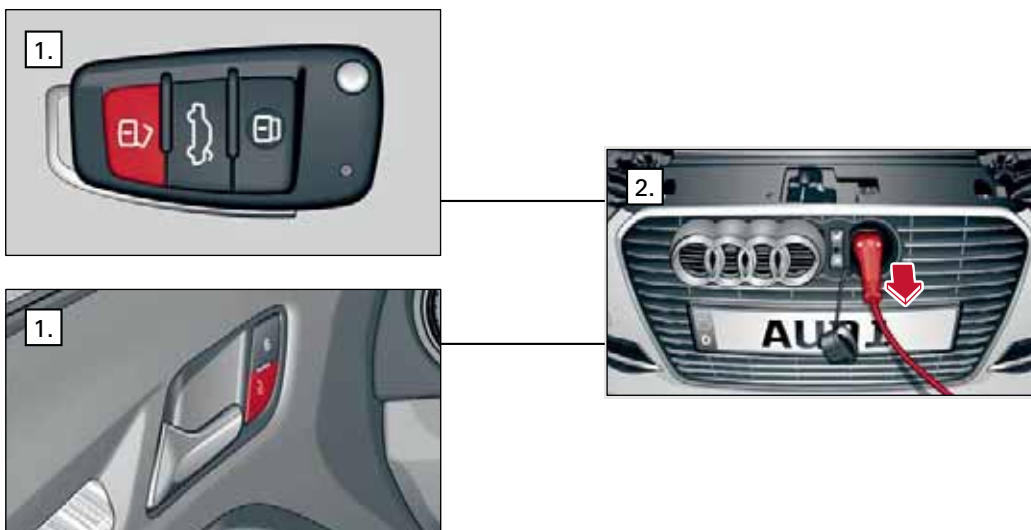







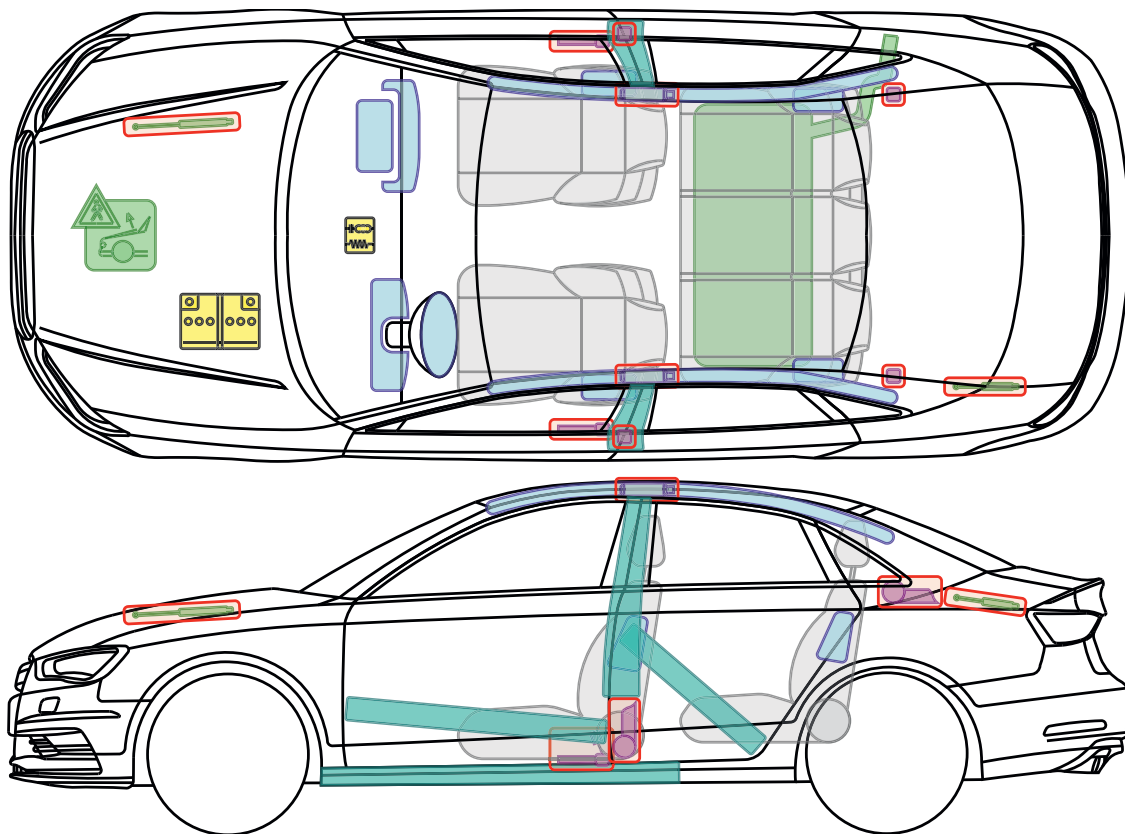

▶ Audi A3 / S3 Limousine

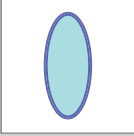
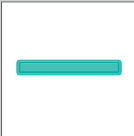
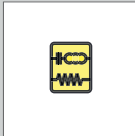
from 2013

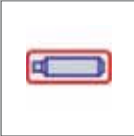

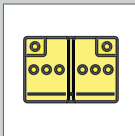
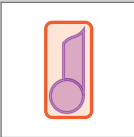
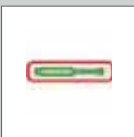
Legend

	Airbag		Reinforcement		Control module		Pedestrian protection system
	Gas generator		Overroll protection		12 V battery		
	Pretensioner		Gas-pressure damper		Fuel tank		



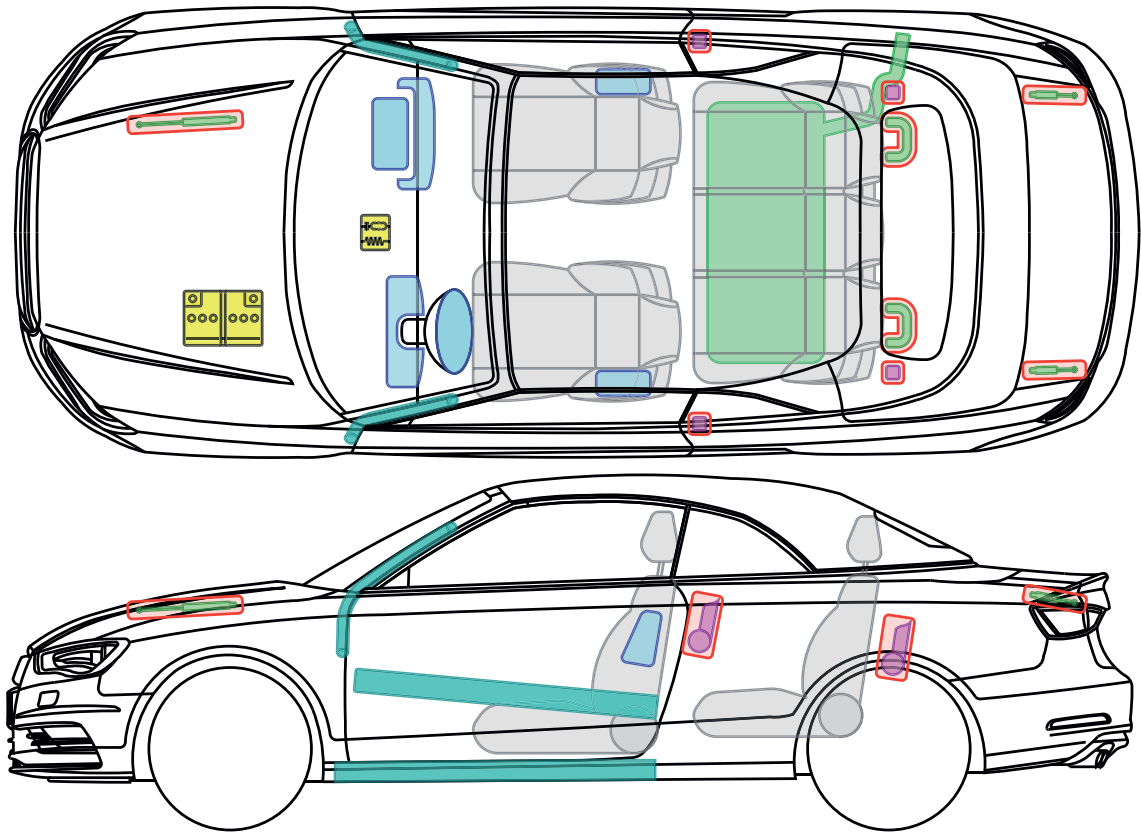

This document is a subject to the copyright of AUDI AG, Ingolstadt. Any duplication, distribution, storage, communication, broadcast and reproduction or transmission of the contents without written approval from AUDI AG is prohibited.

Audi A3 / S3 Cabriolet

from 2013

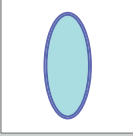
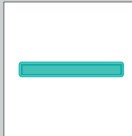
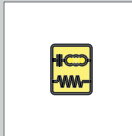
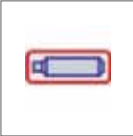

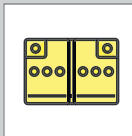
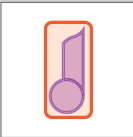
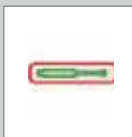
Legend

	Airbag		Reinforcement		Control module
	Gas generator		Rollover protection		Battery
	Pre-tensioner		Gas-pressure damper		Fuel tank

This document is a subject to the copyright of AUDI AG, Ingolstadt. Any duplication, distribution, storage, communication, broadcast and reproduction or transmission of the contents without written approval from AUDI AG is prohibited.



▶ Audi A4 / S4

1995 – 2001

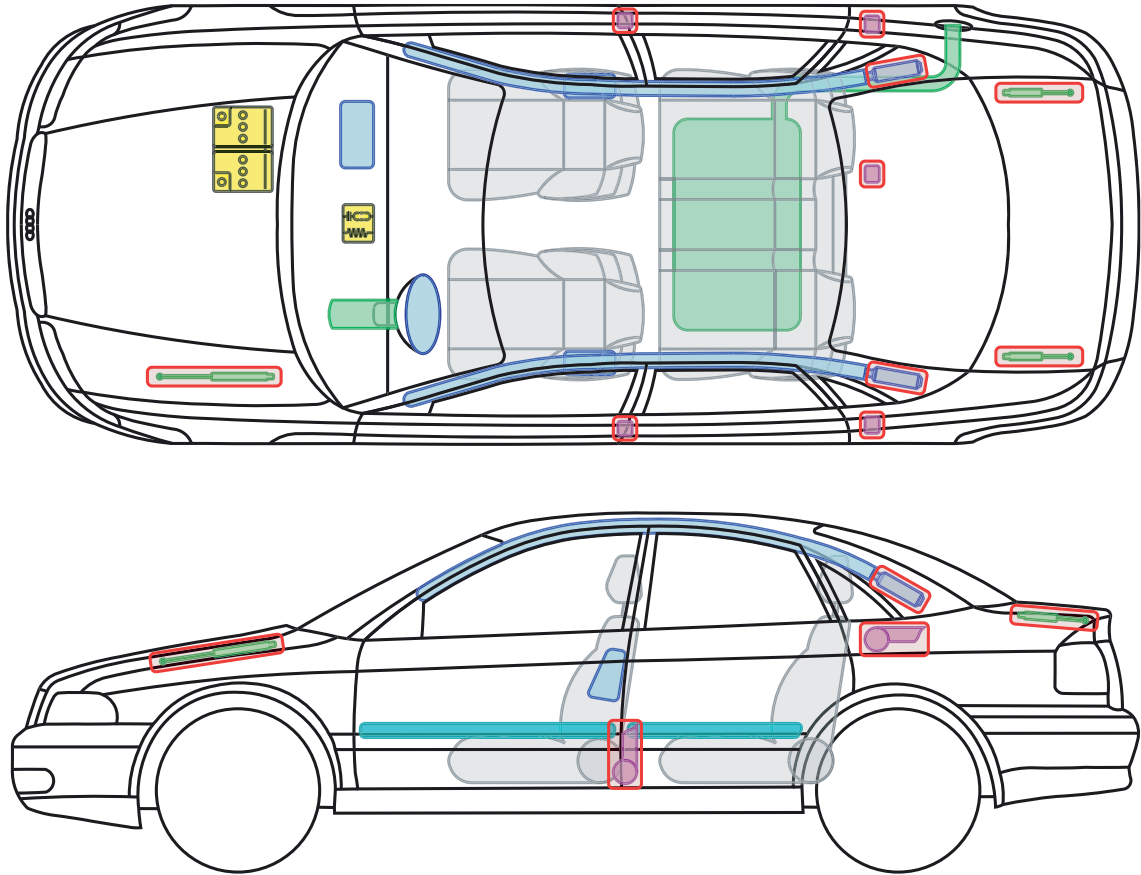

Legend

	Airbag		Reinforce-ment		Control module
	Gas generator		Rollover protection		Battery
	Pre-tensioner		Gas-pressure damper		Fuel tank

This document is a subject to the copyright of AUDI AG, Ingolstadt. Any duplication, distribution, storage, communication, broadcast and reproduction or transmission of the contents without written approval from AUDI AG is prohibited.



▶ Audi A4 / S4 / RS4 Avant

1996 – 2001

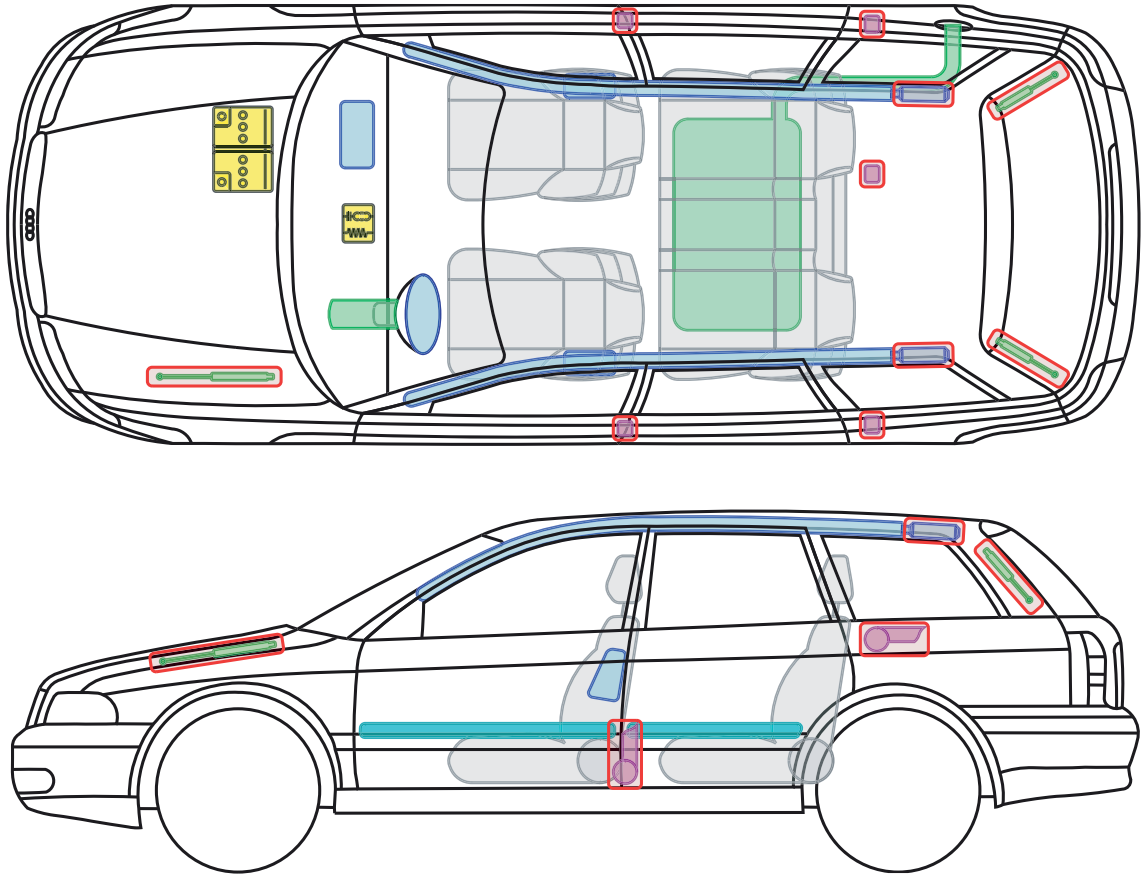

Legend

	Airbag		Reinforce-ment		Control module
	Gas generator		Rollover protection		Battery
	Pretensioner		Gas-pressure damper		Fuel tank

This document is a subject to the copyright of AUDI AG, Ingolstadt. Any duplication, distribution, storage, communication, broadcast and reproduction or transmission of the contents without written approval from AUDI AG is prohibited.



▶ Audi A4 / S4

2001 – 2005

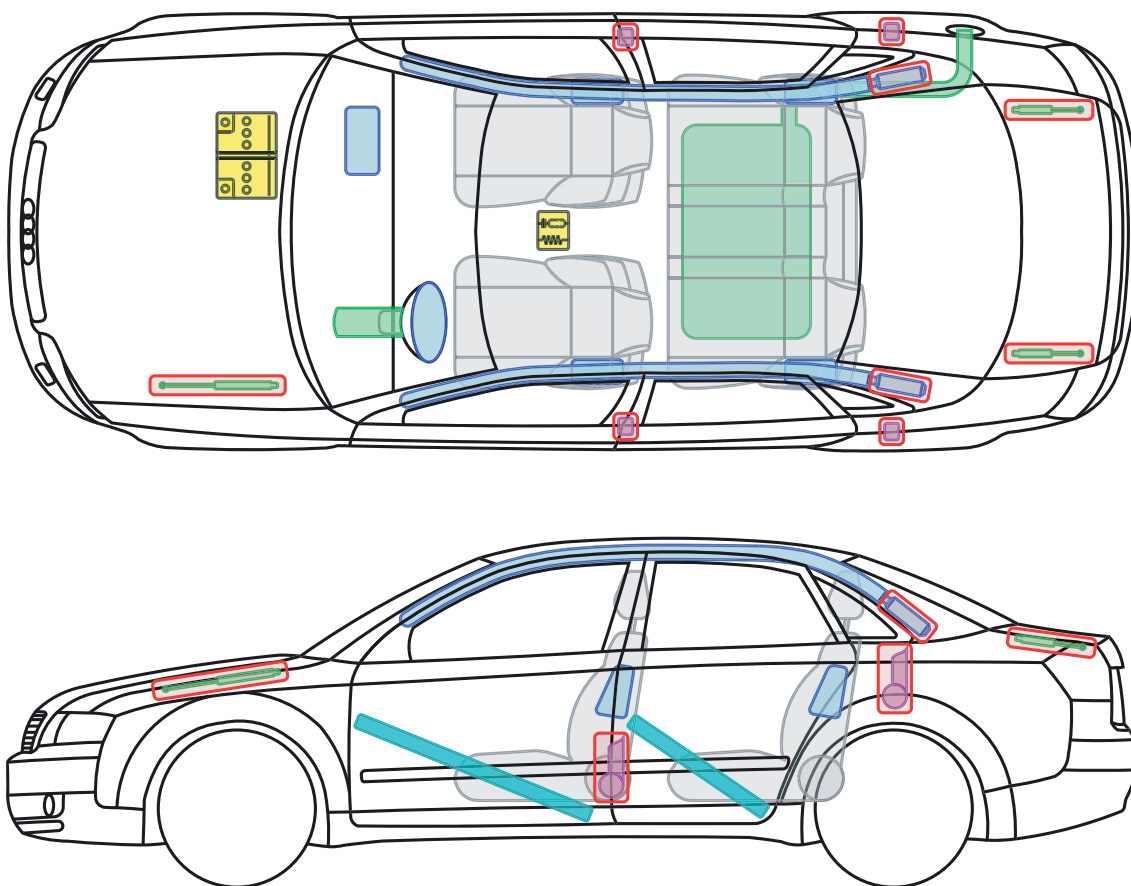

Legend

	Airbag		Reinforce-ment		Control module
	Gas generator		Rollover protection		Battery
	Pre-tensioner		Gas-pressure damper		Fuel tank

This document is a subject to the copyright of AUDI AG, Ingolstadt. Any duplication, distribution, storage, communication, broadcast and reproduction or transmission of the contents without written approval from AUDI AG is prohibited.





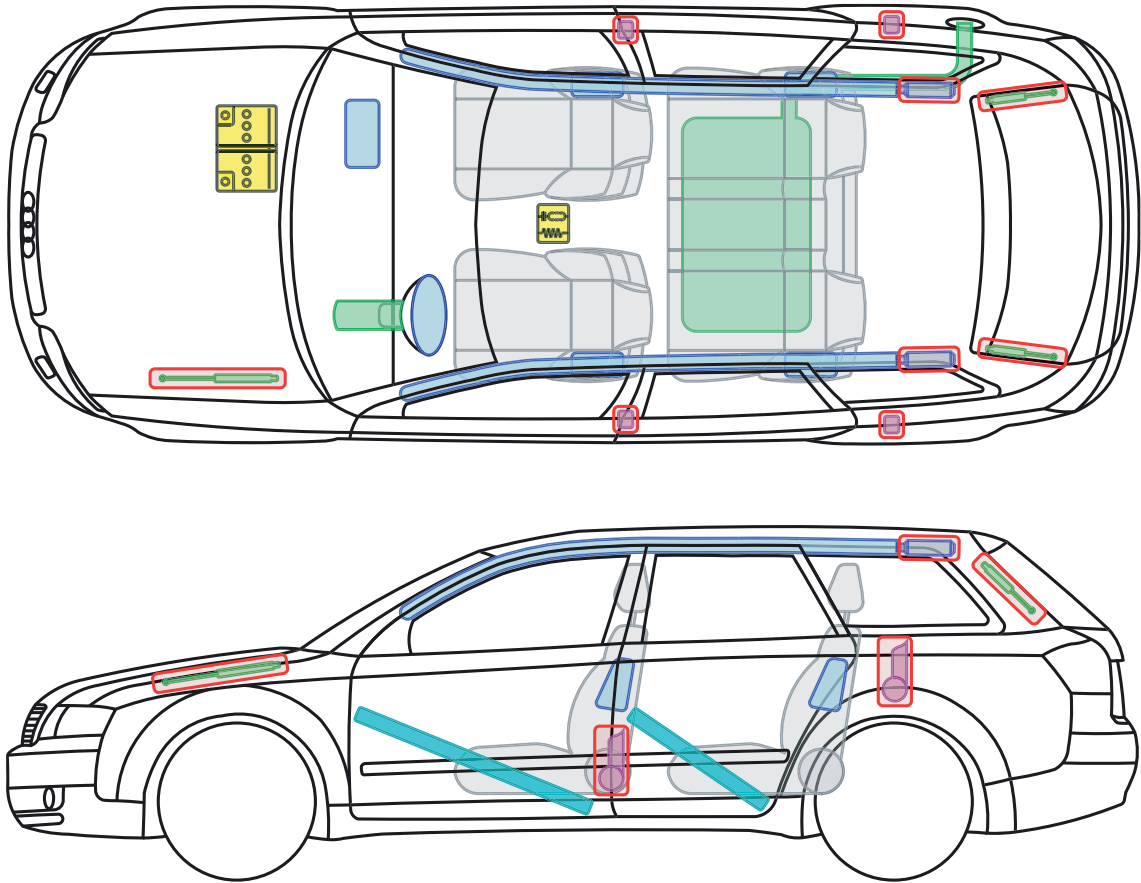

▶ Audi A4 / S4 Avant

2001 – 2005

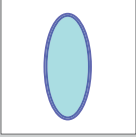
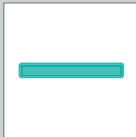
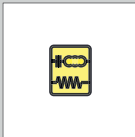
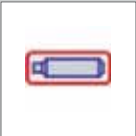

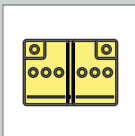
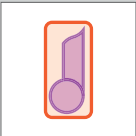
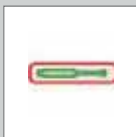
Legend

	Airbag		Reinforcement		Control module
	Gas generator		Rollover protection		Battery
	Pre-tensioner		Gas-pressure damper		Fuel tank

This document is a subject to the copyright of AUDI AG, Ingolstadt. Any duplication, distribution, storage, communication, broadcast and reproduction or transmission of the contents without written approval from AUDI AG is prohibited.



▶ Audi A4 / S4 / RS4

2005 – 2007

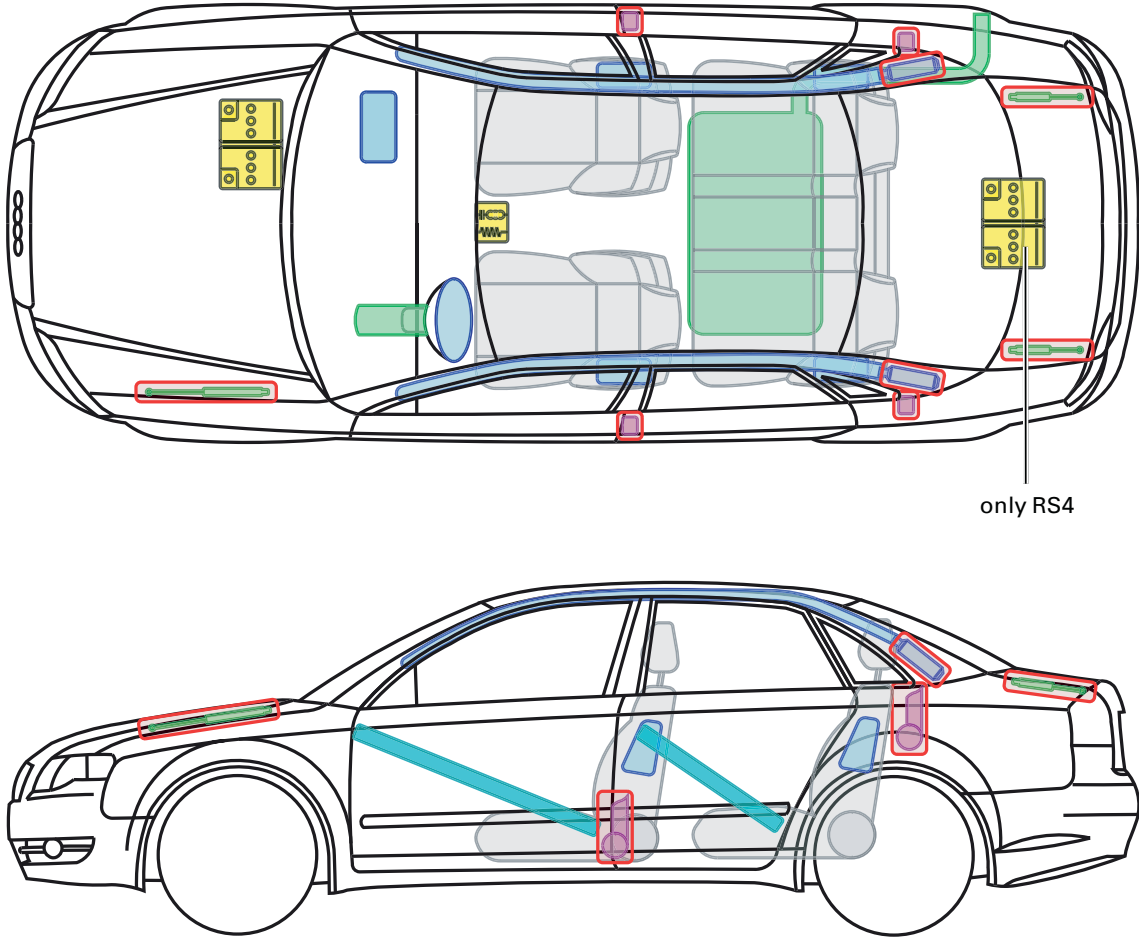

Legend

	Airbag		Reinforcement		Control module
	Gas generator		Roll-over protection		Battery
	Pretensioner		Gas-pressure damper		Fuel tank

This document is a subject to the copyright of AUDI AG, Ingolstadt. Any duplication, distribution, storage, communication, broadcast and reproduction or transmission of the contents without written approval from AUDI AG is prohibited.







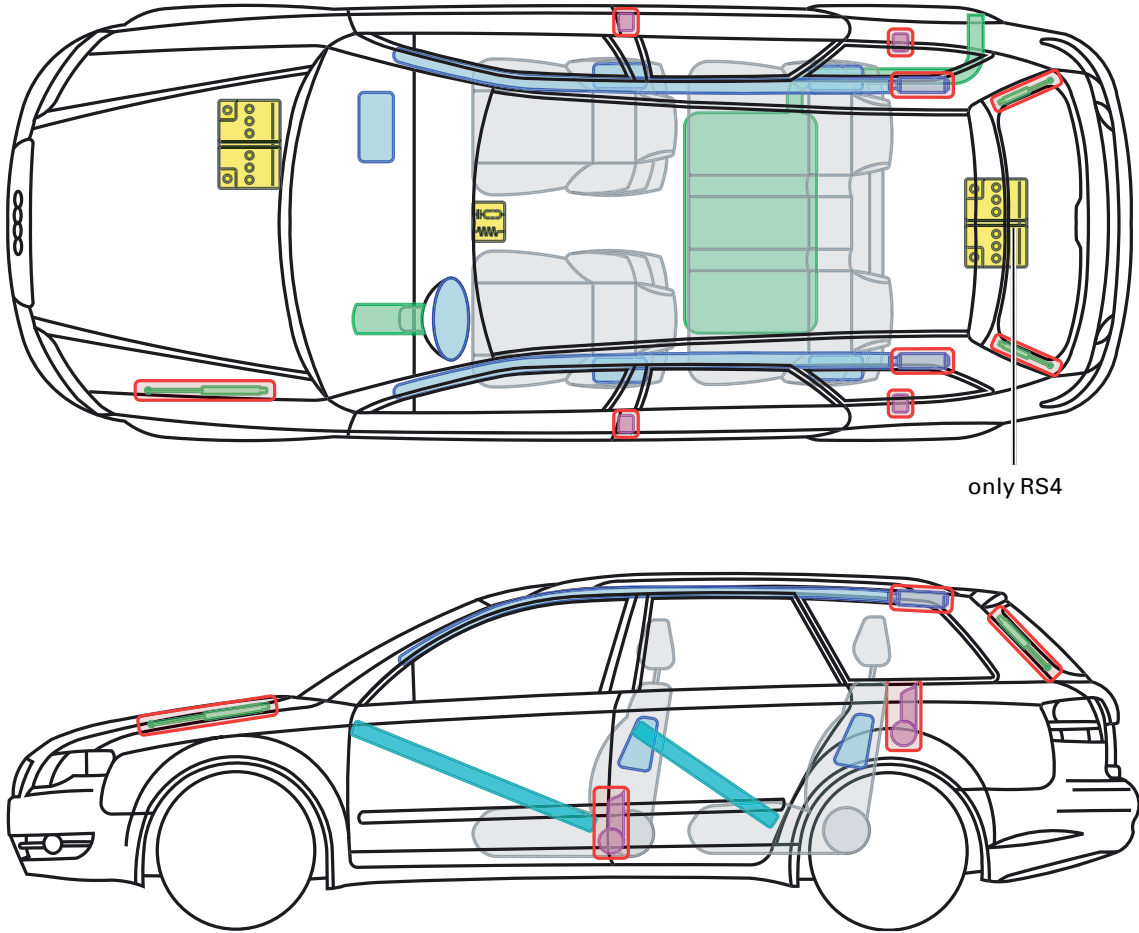

▶ Audi A4 / S4 / RS4 Avant

2005 – 2008

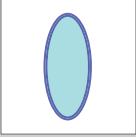
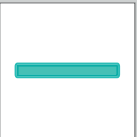

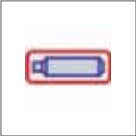
only RS4

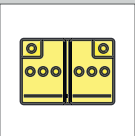
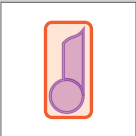
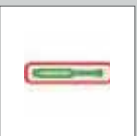
Legend

	Airbag		Reinforce-ment		Control module
	Gas generator		Rollover protection		Battery
	Pre-tensioner		Gas-pressure damper		Fuel tank

This document is a subject to the copyright of AUDI AG, Ingolstadt. Any duplication, distribution, storage, communication, broadcast and reproduction or transmission of the contents without written approval from AUDI AG is prohibited.





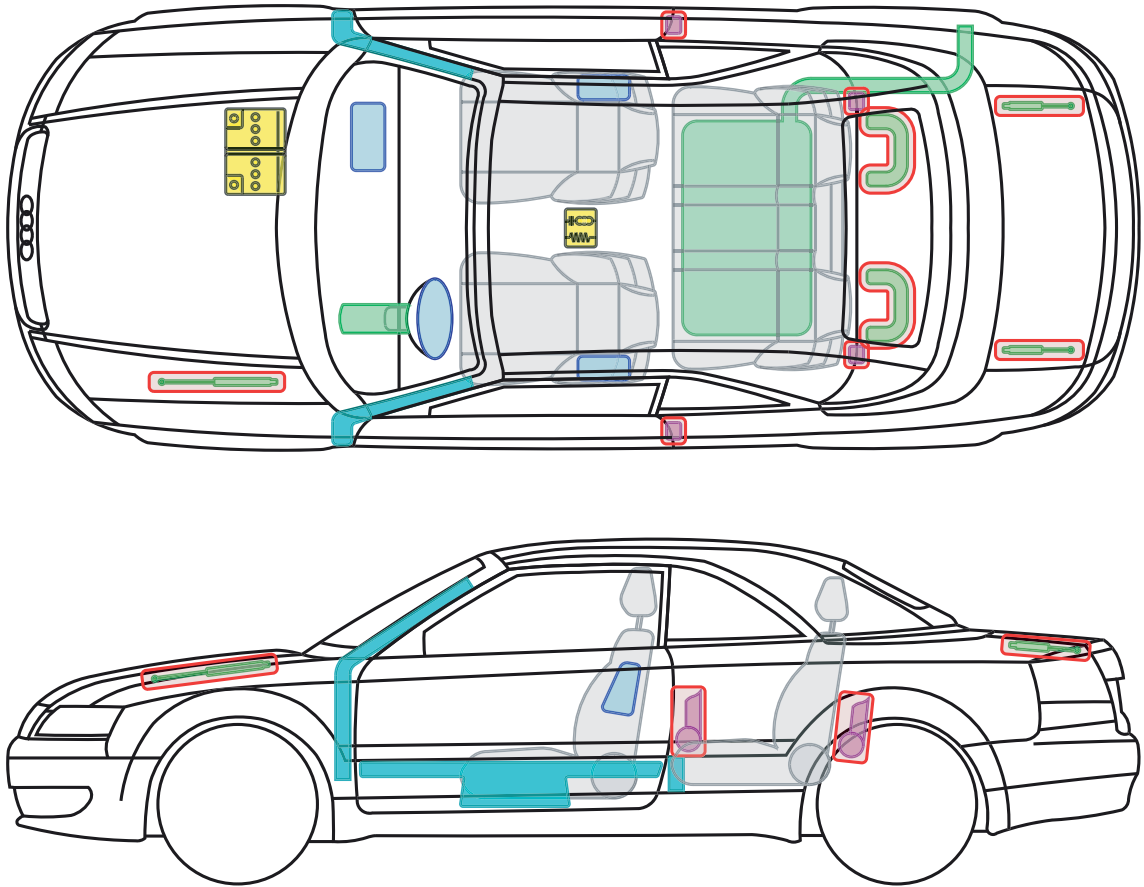

▶ Audi A4 / S4 Cabriolet

2002 – 2005

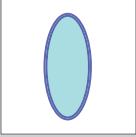
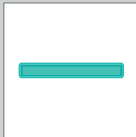
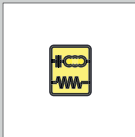
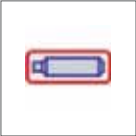

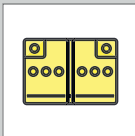
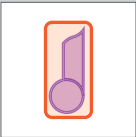
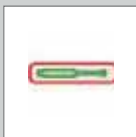
Legend

	Airbag		Reinforce-ment		Control module
	Gas generator		Rollover protection		Battery
	Pre-tensioner		Gas-pressure damper		Fuel tank

This document is a subject to the copyright of AUDI AG, Ingolstadt. Any duplication, distribution, storage, communication, broadcast and reproduction or transmission of the contents without written approval from AUDI AG is prohibited.





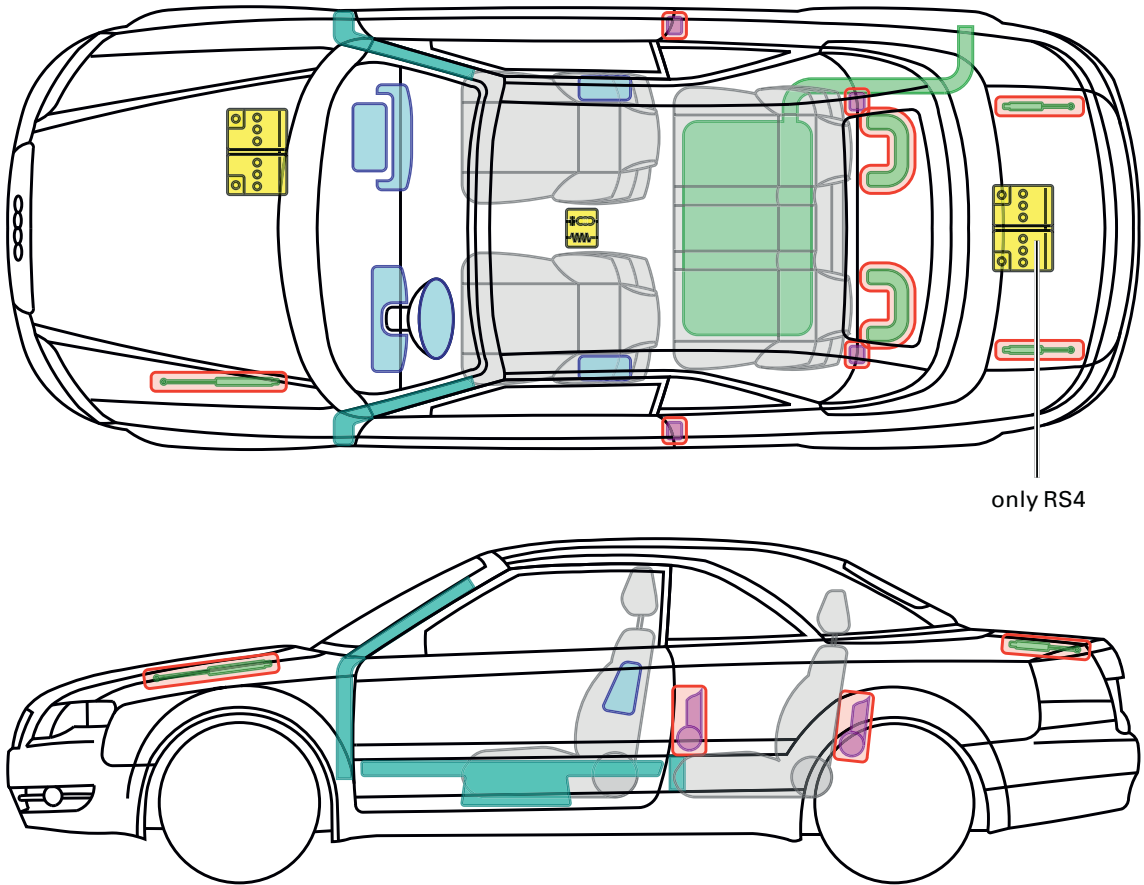

▶ Audi A4 / S4 / RS4 Cabriolet

2005 – 2009

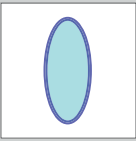
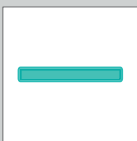
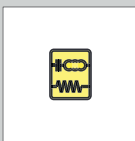
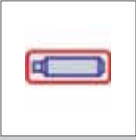

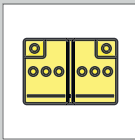
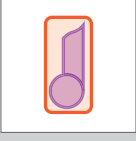
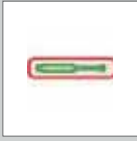
Legend

	Airbag		Reinforcement		Control module
	Gas generator		Rollover protection		Battery
	Pre-tensioner		Gas-pressure damper		Fuel tank

This document is a subject to the copyright of AUDI AG, Ingolstadt. Any duplication, distribution, storage, communication, broadcast and reproduction or transmission of the contents without written approval from AUDI AG is prohibited.







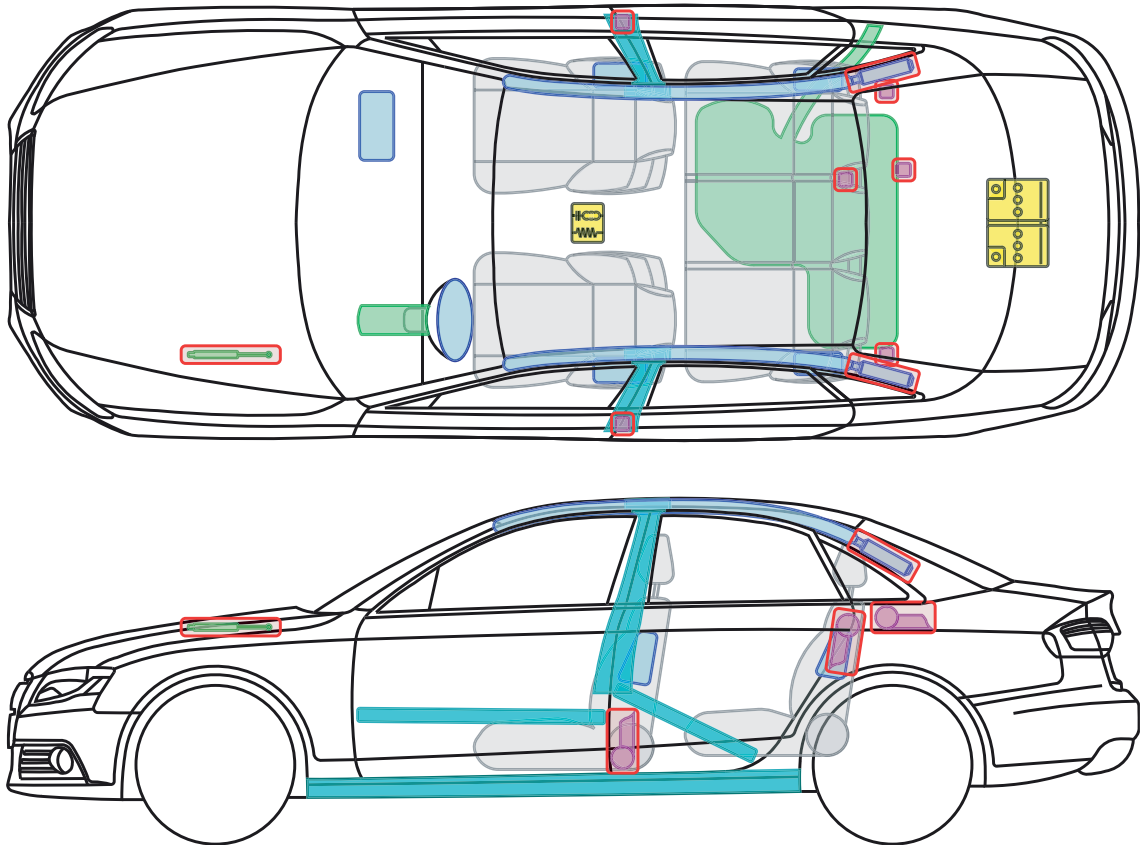

▶ Audi A4 / S4

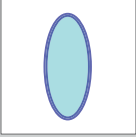
2007 – 2012

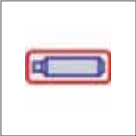

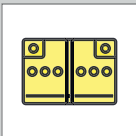
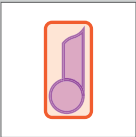
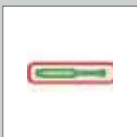
Legend

	Airbag		Reinforcement		Control module
	Gas generator		Rollover protection		Battery
	Pretensioner		Gas-pressure damper		Fuel tank

This document is a subject to the copyright of AUDI AG, Ingolstadt. Any duplication, distribution, storage, communication, broadcast and reproduction or transmission of the contents without written approval from AUDI AG is prohibited.







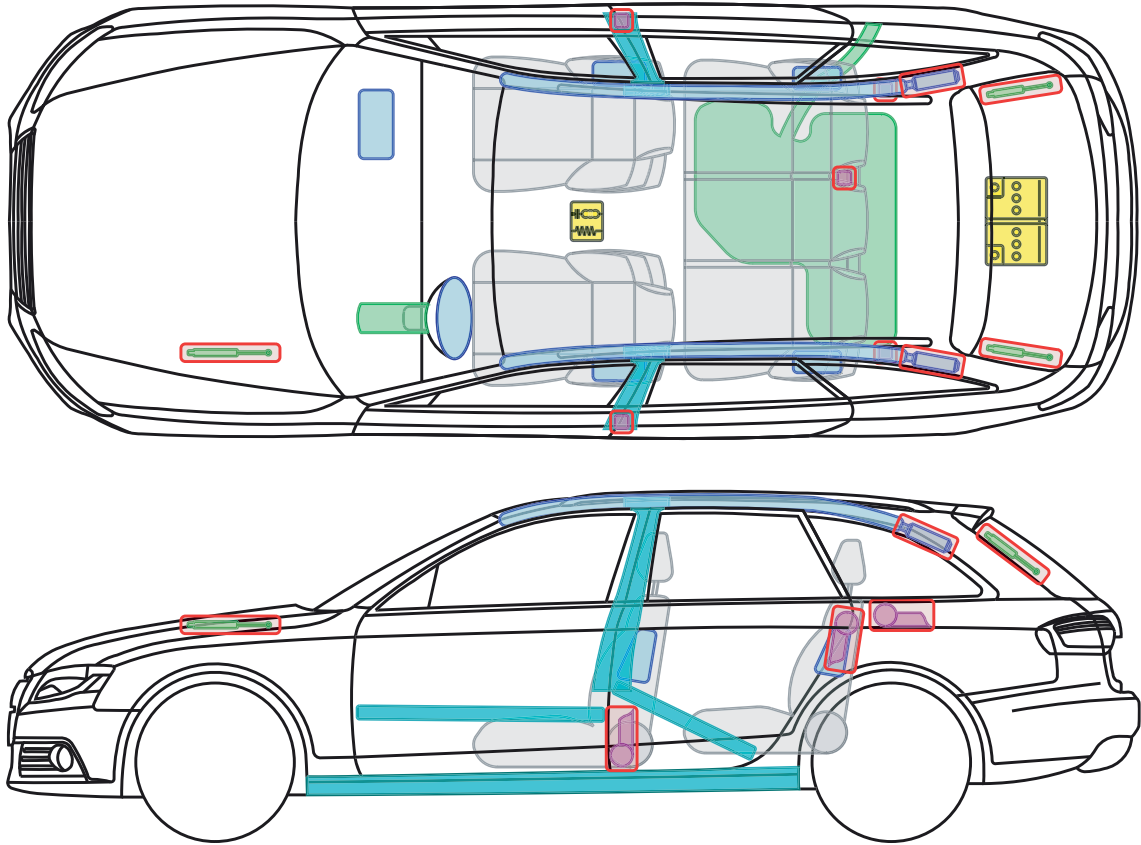

▶ Audi A4 /S4 Avant

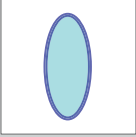
2008 – 2012

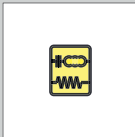
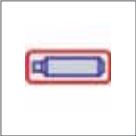

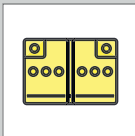
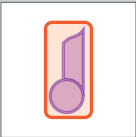
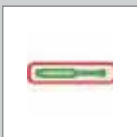
Legend

	Airbag		Reinforcement		Control module
	Gas generator		Rollover protection		Battery
	Pre-tensioner		Gas-pressure damper		Fuel tank

This document is a subject to the copyright of AUDI AG, Ingolstadt. Any duplication, distribution, storage, communication, broadcast and reproduction or transmission of the contents without written approval from AUDI AG is prohibited.







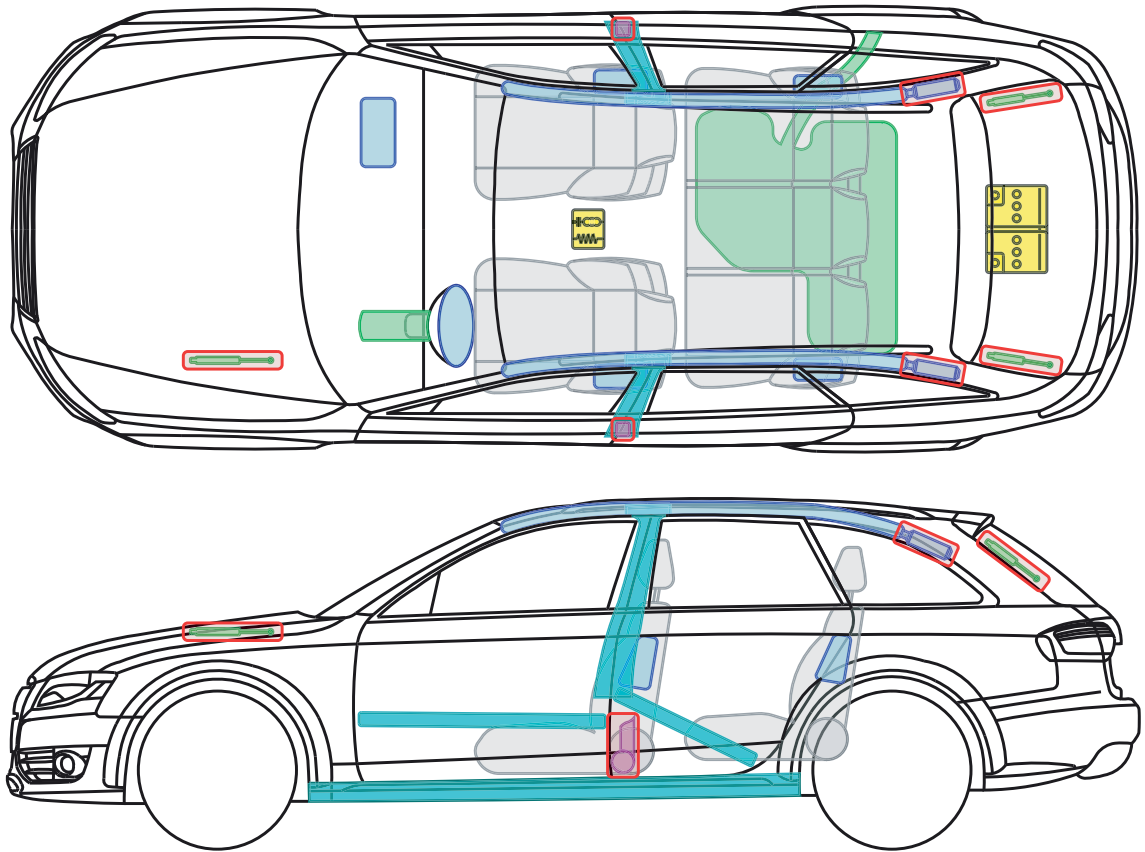

▶ Audi A4 allroad

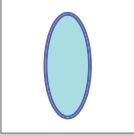
2009 – 2012

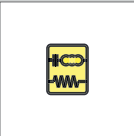
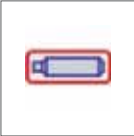

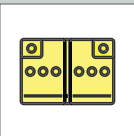
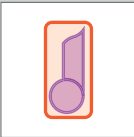
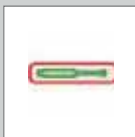
Legend

	Airbag		Reinforcement		Control module
	Gas generator		Rollover protection		Battery
	Pre-tensioner		Gas-pressure damper		Fuel tank

This document is a subject to the copyright of AUDI AG, Ingolstadt. Any duplication, distribution, storage, communication, broadcast and reproduction or transmission of the contents without written approval from AUDI AG is prohibited.







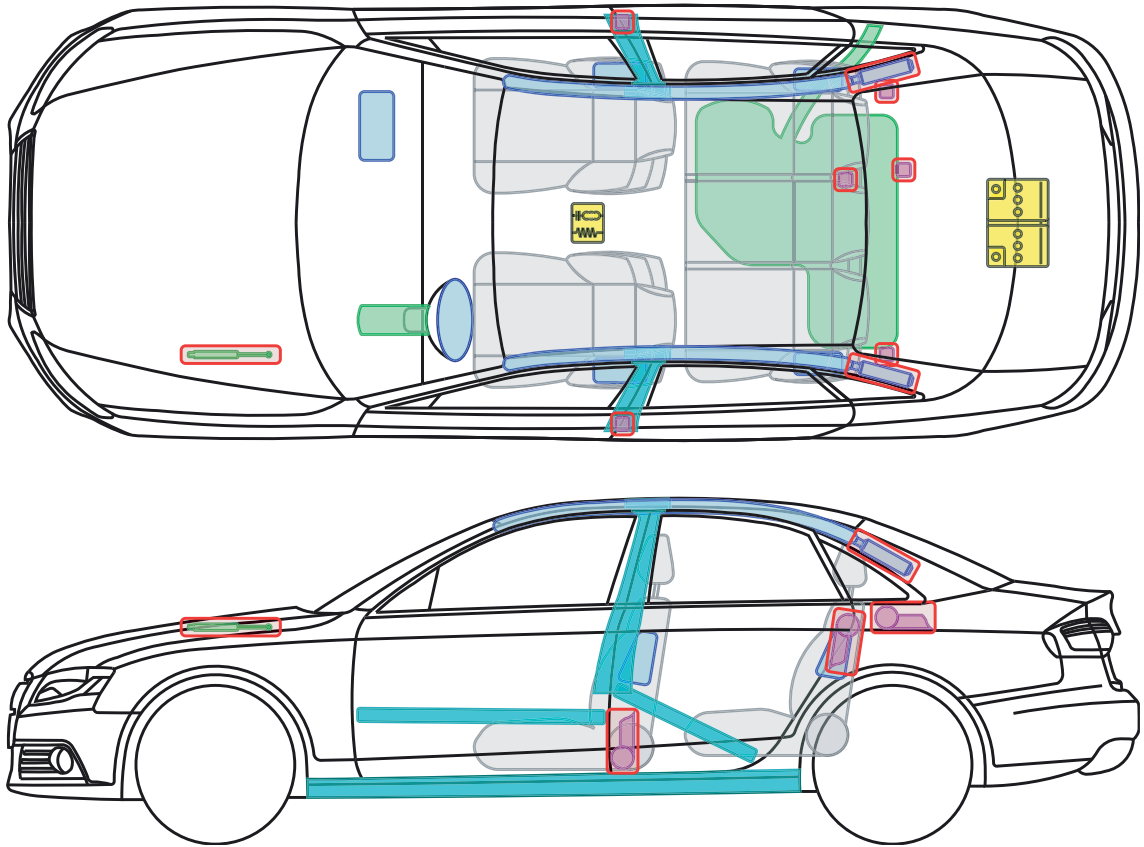

▶ Audi A4 / S4

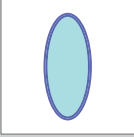
from 2012

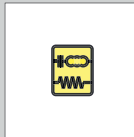
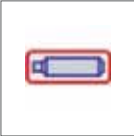

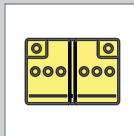
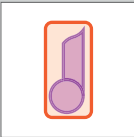
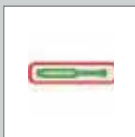
Legend

	Airbag		Reinforcement		Control module
	Gas generator		Rollover protection		Battery
	Pretensioner		Gas-pressure damper		Fuel tank

This document is a subject to the copyright of AUDI AG, Ingolstadt. Any duplication, distribution, storage, communication, broadcast and reproduction or transmission of the contents without written approval from AUDI AG is prohibited.







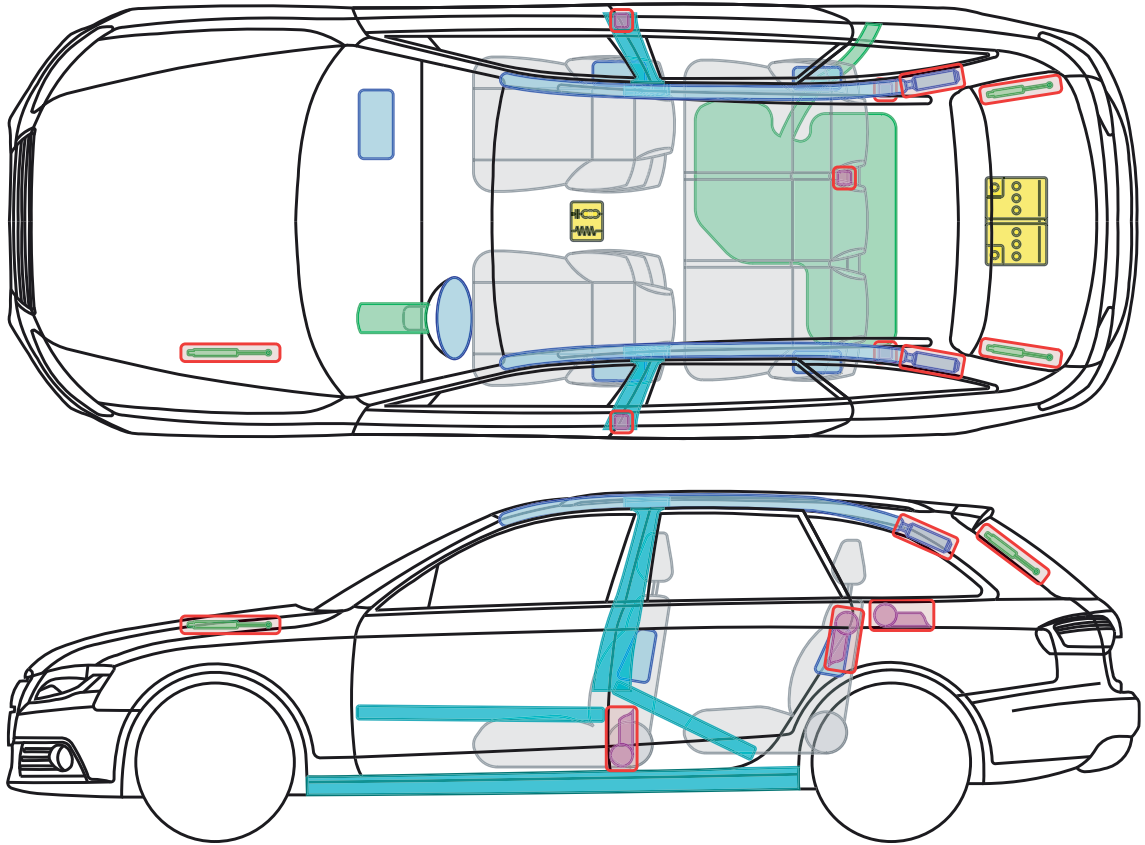

▶ Audi A4 / S4 / RS4 Avant

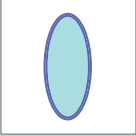
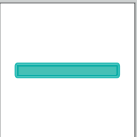
from 2012

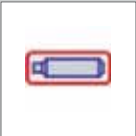

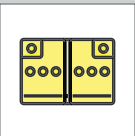
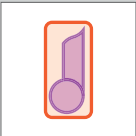
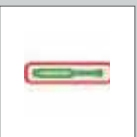
Legend

	Airbag		Reinforcement		Control module
	Gas generator		Rollover protection		Battery
	Pre-tensioner		Gas-pressure damper		Fuel tank

This document is a subject to the copyright of AUDI AG, Ingolstadt. Any duplication, distribution, storage, communication, broadcast and reproduction or transmission of the contents without written approval from AUDI AG is prohibited.







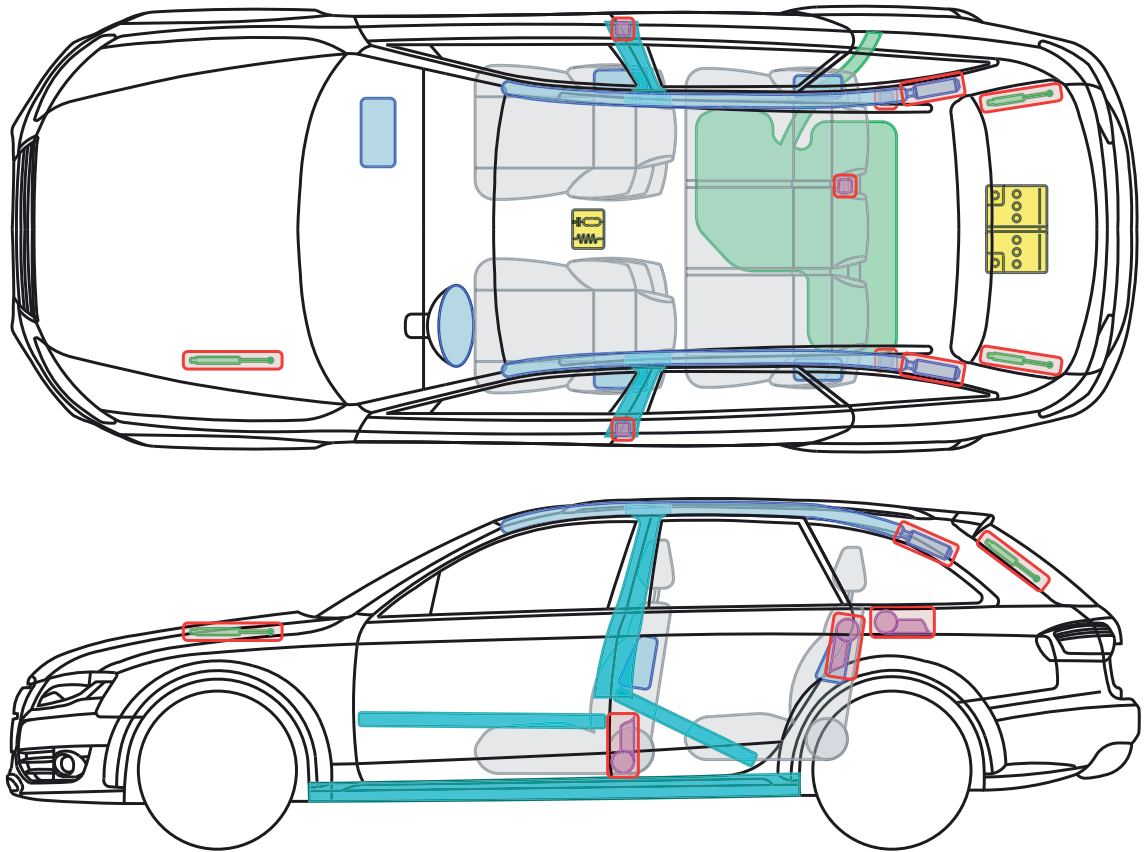

▶ Audi A4 allroad

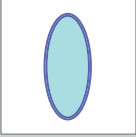
from 2012

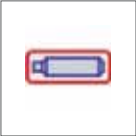

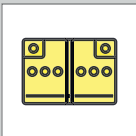
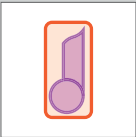
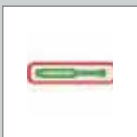
Legend

	Airbag		Reinforcement		Control module
	Gas generator		Rollover protection		Battery
	Pre-tensioner		Gas-pressure damper		Fuel tank

This document is a subject to the copyright of AUDI AG, Ingolstadt. Any duplication, distribution, storage, communication, broadcast and reproduction or transmission of the contents without written approval from AUDI AG is prohibited.



▶ Audi A5 / S5 / RS5

2007 – 2011

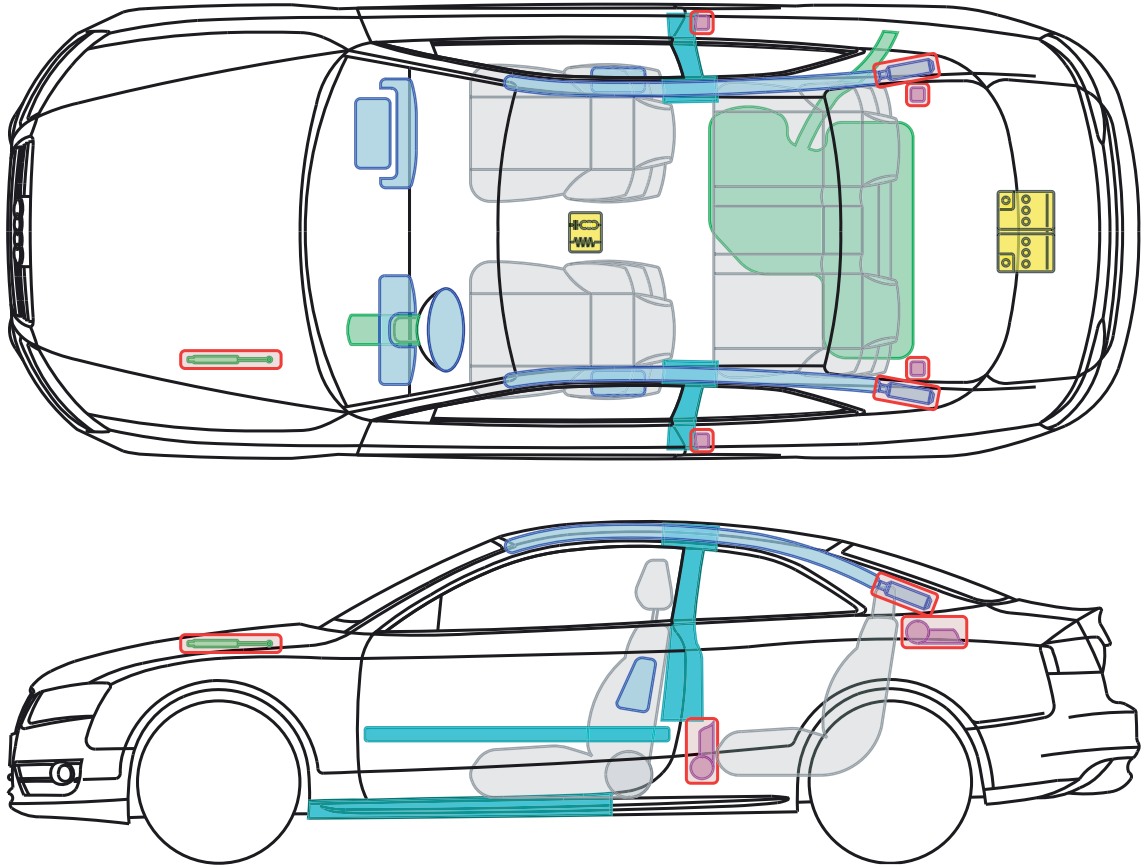

Legend

	Airbag		Reinforcement		Control module
	Gas generator		Rollover protection		Battery
	Pre-tensioner		Gas-pressure damper		Fuel tank

This document is a subject to the copyright of AUDI AG, Ingolstadt. Any duplication, distribution, storage, communication, broadcast and reproduction or transmission of the contents without written approval from AUDI AG is prohibited.







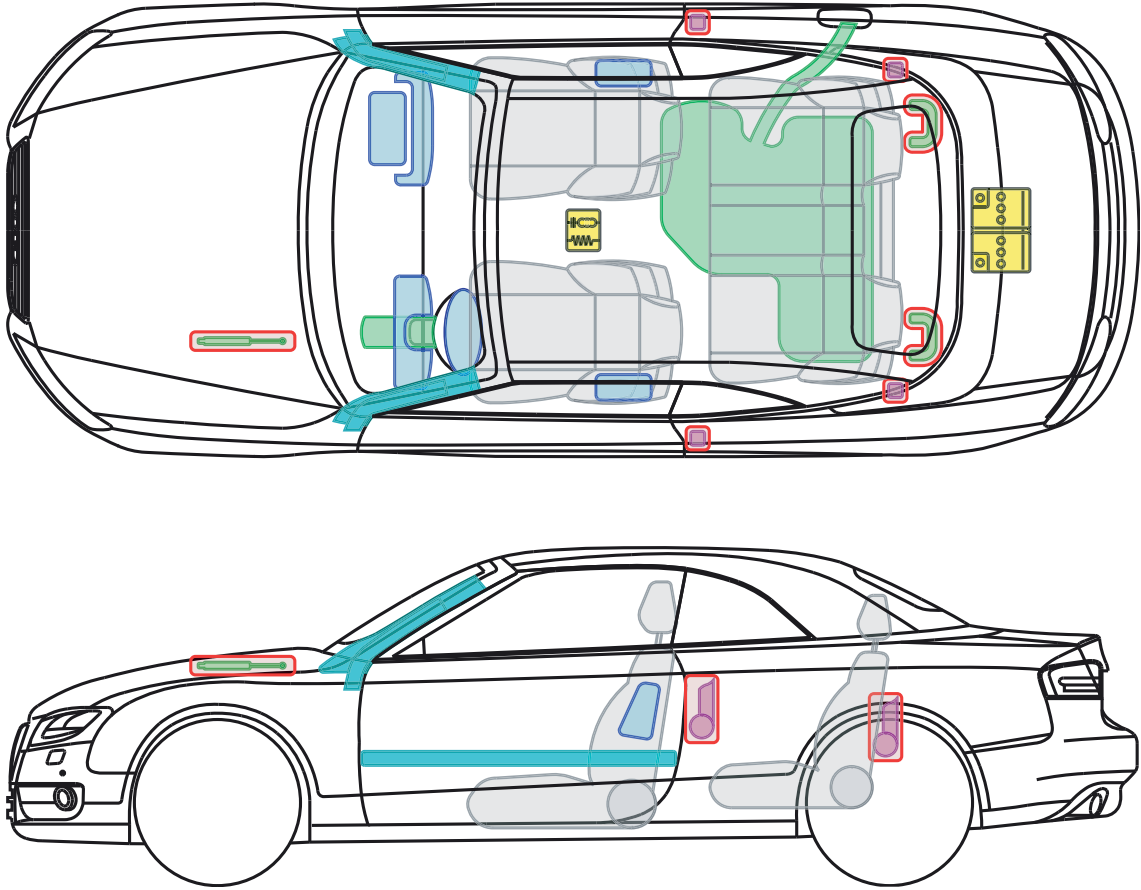

▶ Audi A5 / S5 Cabriolet

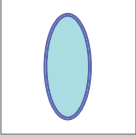
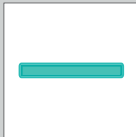
2009 – 2011

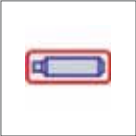

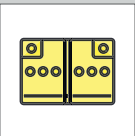
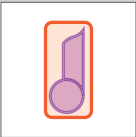
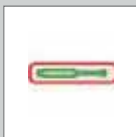
Legend

	Airbag		Reinforce-ment		Control module
	Gas generator		Rollover protection		Battery
	Pretensioner		Gas-pressure damper		Fuel tank

This document is a subject to the copyright of AUDI AG, Ingolstadt. Any duplication, distribution, storage, communication, broadcast and reproduction or transmission of the contents without written approval from AUDI AG is prohibited.





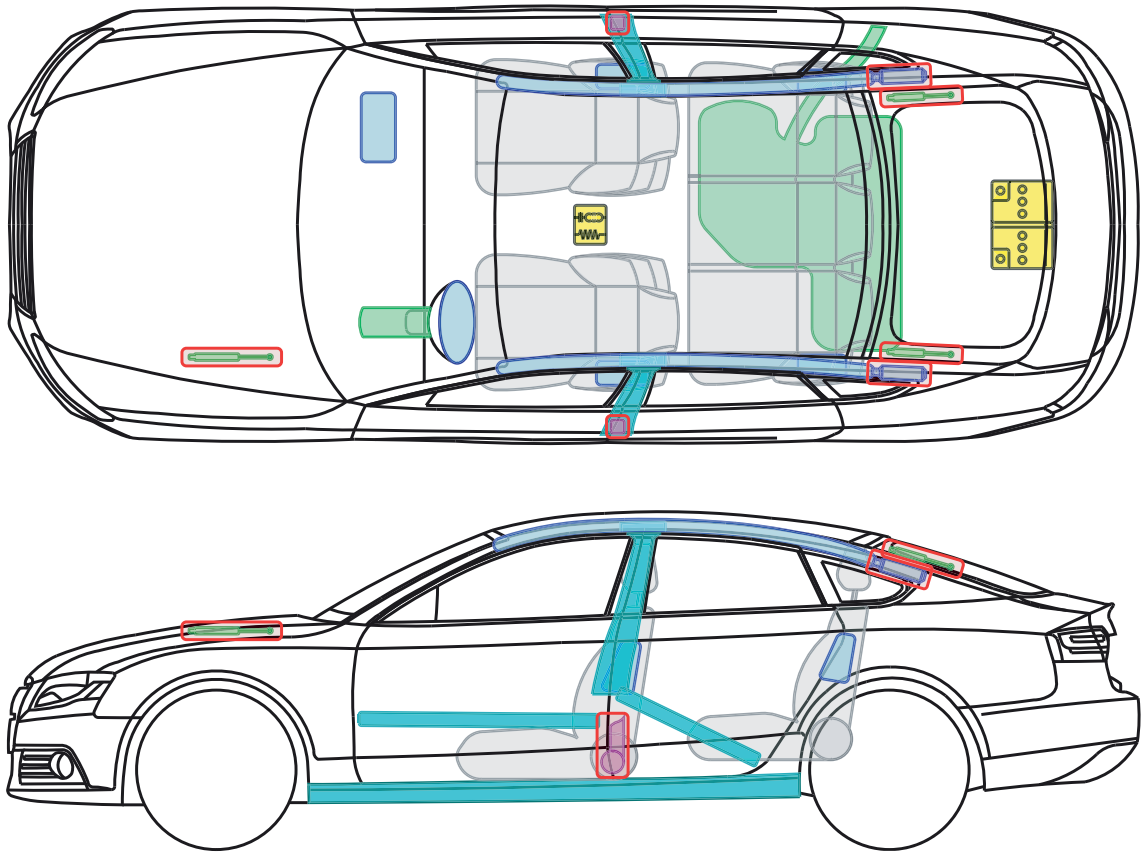

▶ Audi A5 / S5 Sportback

2009 – 2011

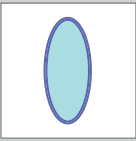
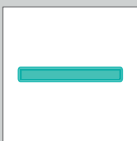
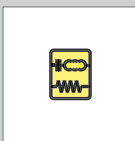
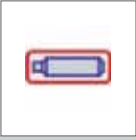

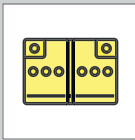
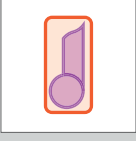
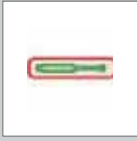
Legend

	Airbag		Reinforcement		Control module
	Gas generator		Rollover protection		Battery
	Pre-tensioner		Gas-pressure damper		Fuel tank

This document is a subject to the copyright of AUDI AG, Ingolstadt. Any duplication, distribution, storage, communication, broadcast and reproduction or transmission of the contents without written approval from AUDI AG is prohibited.







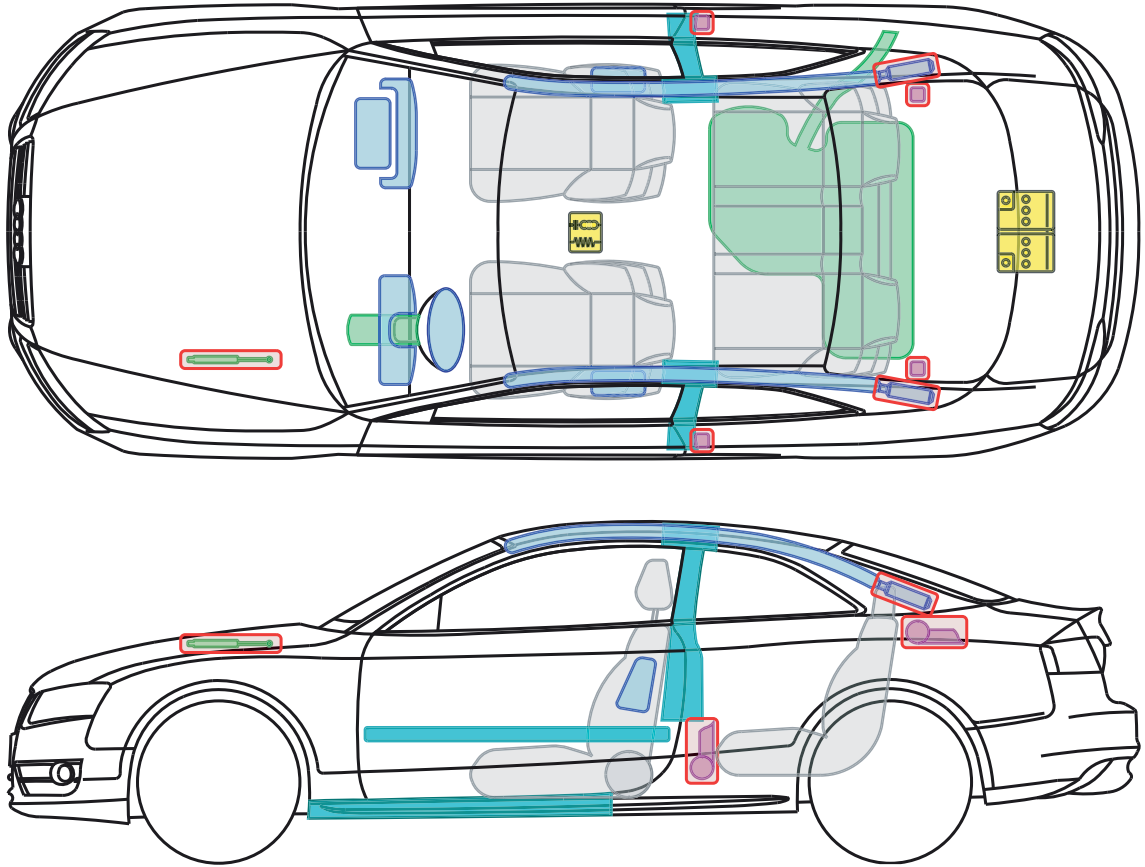

▶ Audi A5 / S5 / RS5

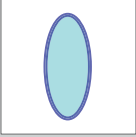
from 2011

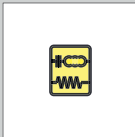
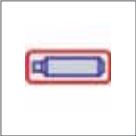

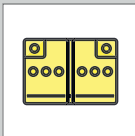
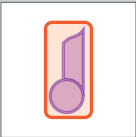
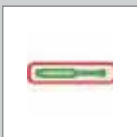
Legend

	Airbag		Reinforcement		Control module
	Gas generator		Rollover protection		Battery
	Pre-tensioner		Gas-pressure damper		Fuel tank

This document is a subject to the copyright of AUDI AG, Ingolstadt. Any duplication, distribution, storage, communication, broadcast and reproduction or transmission of the contents without written approval from AUDI AG is prohibited.



▶ Audi A5 / S5 / RS5 Cabriolet

from 2011

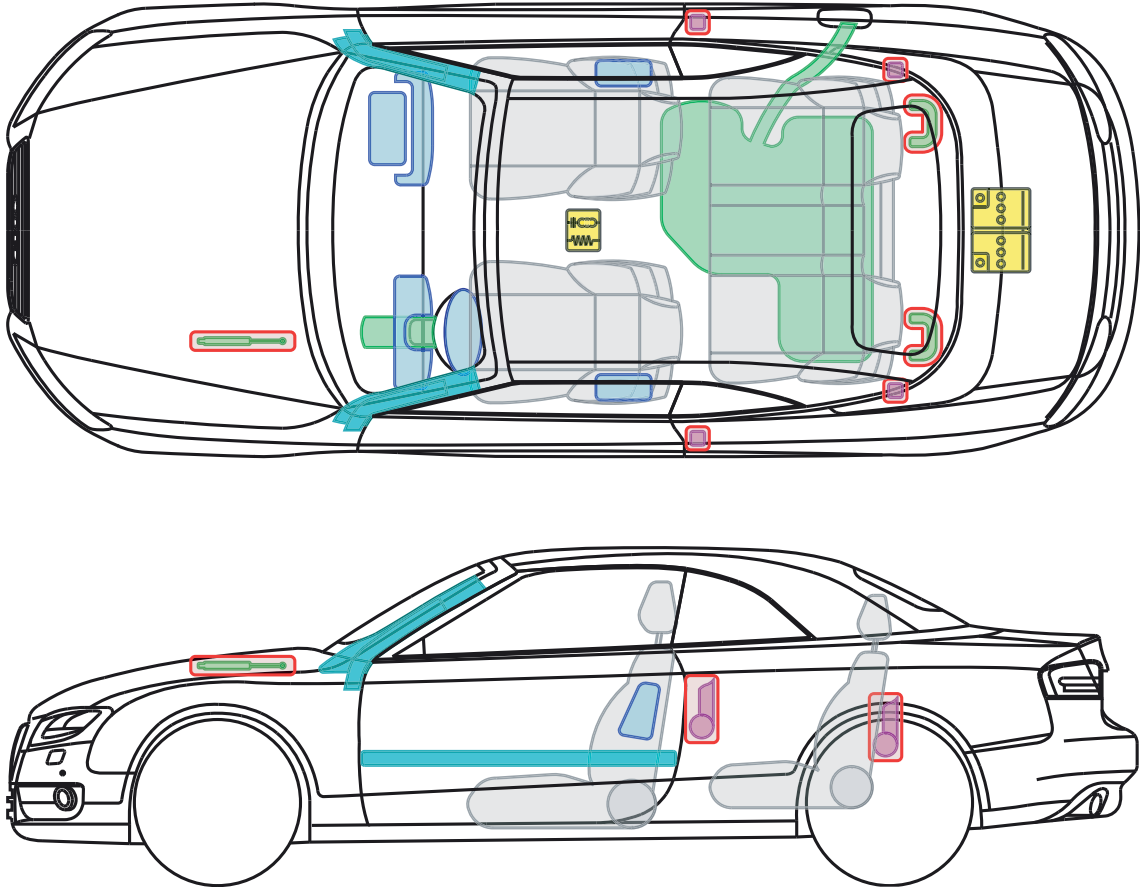

Legend

	Airbag		Reinforce-ment		Control module
	Gas generator		Rollover protection		Battery
	Pre-tensioner		Gas-pressure damper		Fuel tank

This document is a subject to the copyright of AUDI AG, Ingolstadt. Any duplication, distribution, storage, communication, broadcast and reproduction or transmission of the contents without written approval from AUDI AG is prohibited.





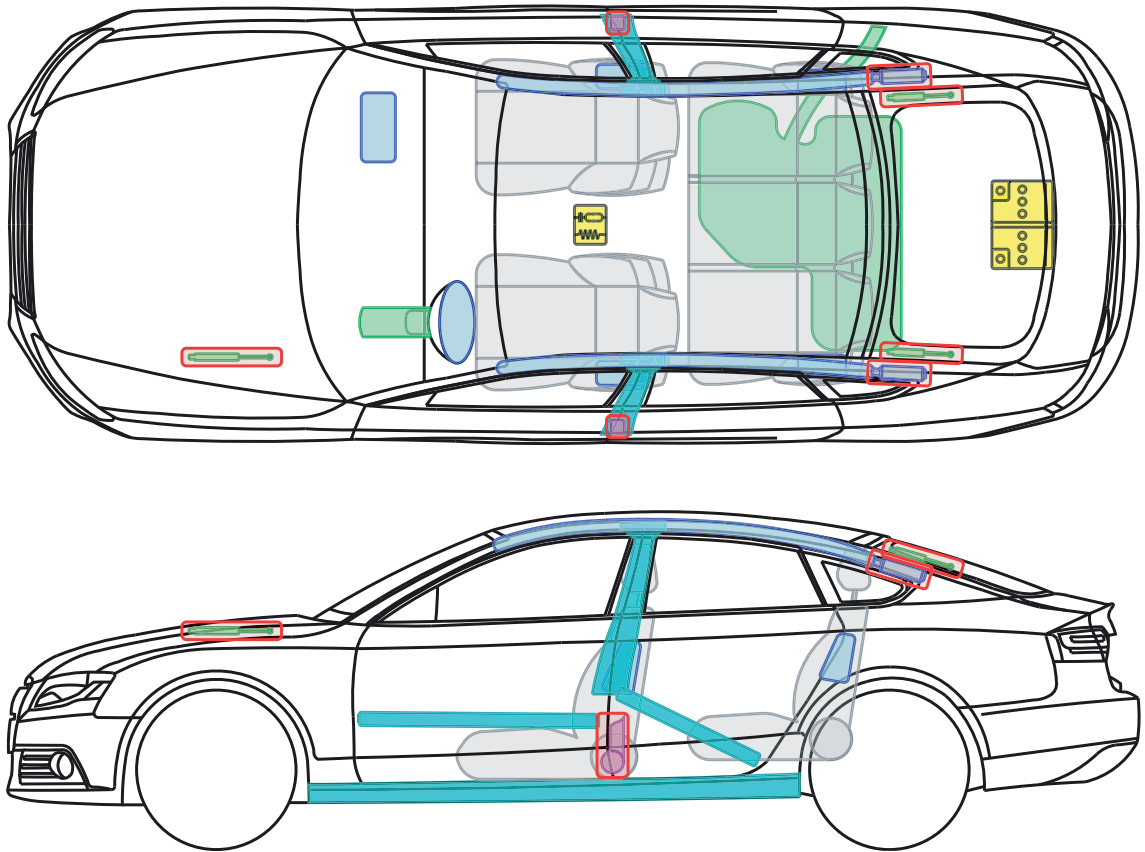

▶ Audi A5 / S5 Sportback

from 2011

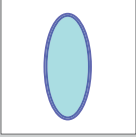
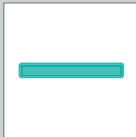
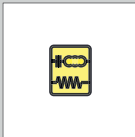
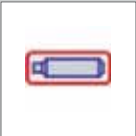

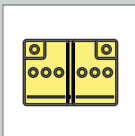
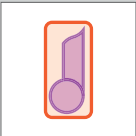
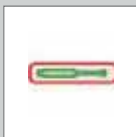
Legend

	Airbag		Reinforce-ment		Control module
	Gas generator		Rollover protection		Battery
	Pre-tensioner		Gas-pressure damper		Fuel tank

This document is a subject to the copyright of AUDI AG, Ingolstadt. Any duplication, distribution, storage, communication, broadcast and reproduction or transmission of the contents without written approval from AUDI AG is prohibited.



▶ Audi A6 / S6 / RS6

1997 – 2004

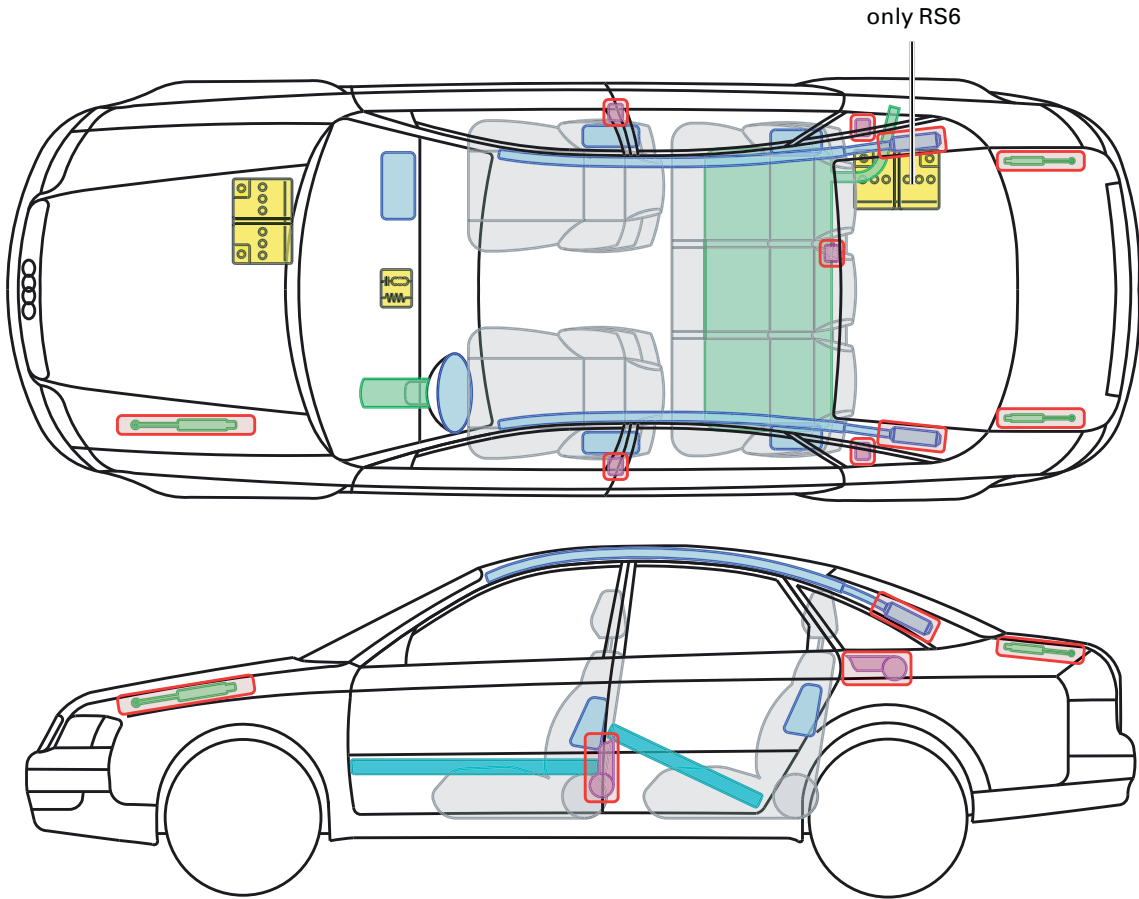

Legend

	Airbag		Reinforcement		Control module
	Gas generator		Rollover protection		Battery
	Pre-tensioner		Gas-pressure damper		Fuel tank





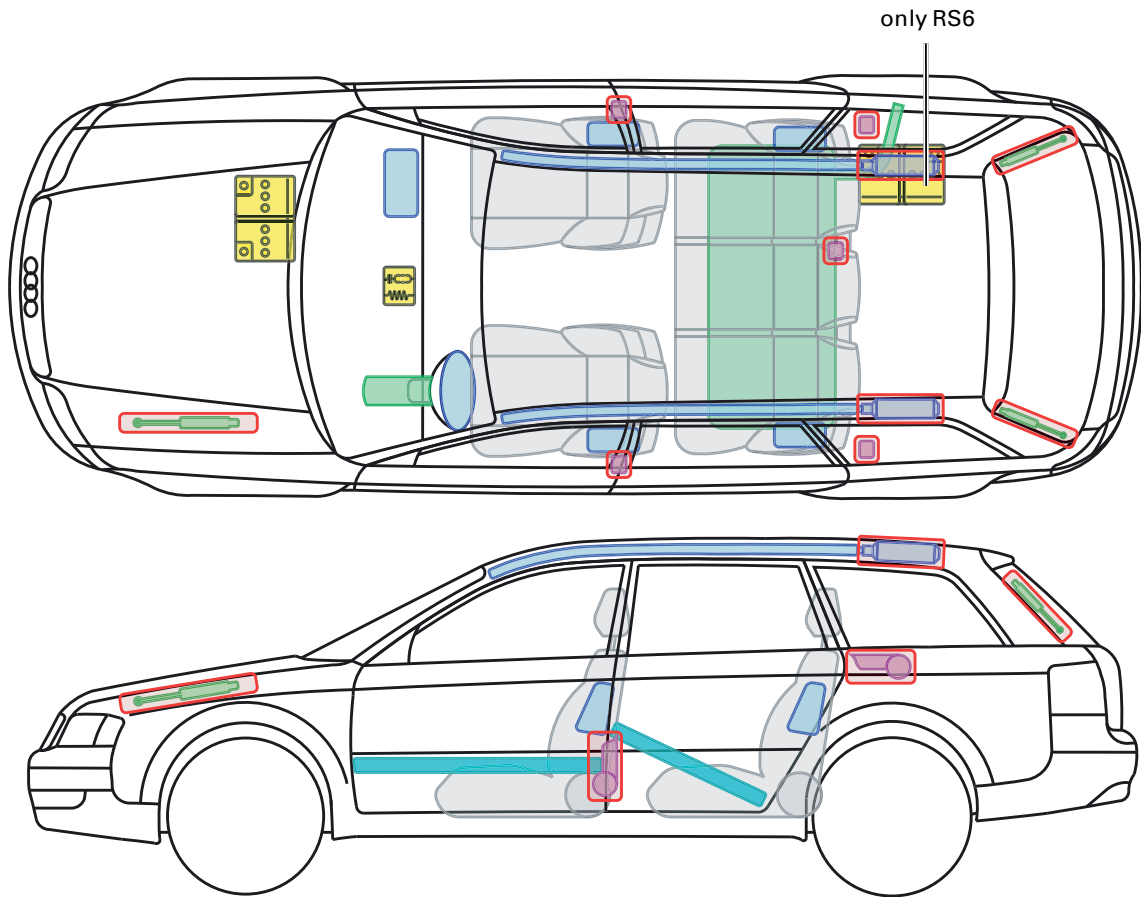

This document is a subject to the copyright of AUDI AG, Ingolstadt. Any duplication, distribution, storage, communication, broadcast and reproduction or transmission of the contents without written approval from AUDI AG is prohibited.

Audi A6 / S6 / RS6 Avant

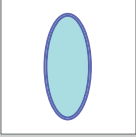
1998 – 2004

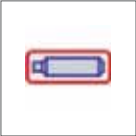

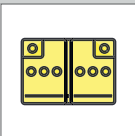
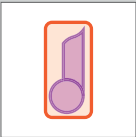
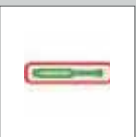
Legend

	Airbag		Reinforcement		Control module
	Gas generator		Rollover protection		Battery
	Pre-tensioner		Gas-pressure damper		Fuel tank

This document is a subject to the copyright of AUDI AG, Ingolstadt. Any duplication, distribution, storage, communication, broadcast and reproduction or transmission of the contents without written approval from AUDI AG is prohibited.







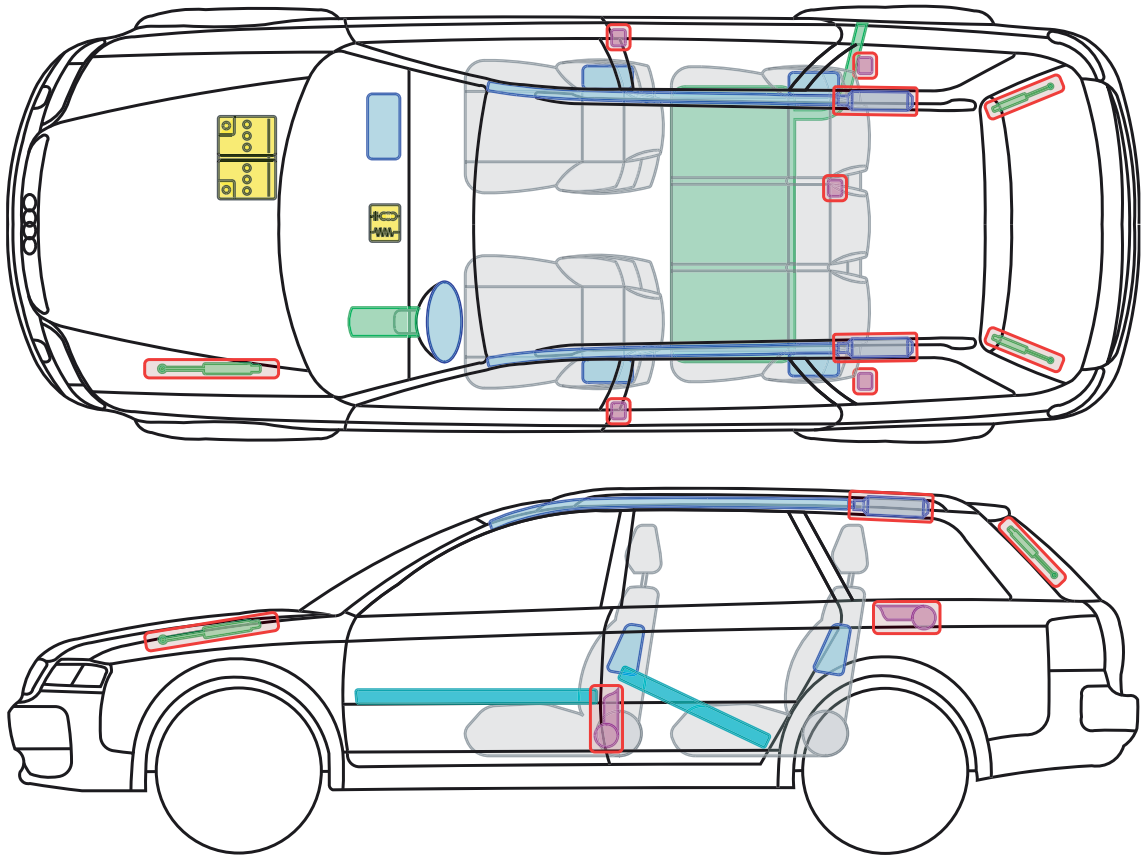

▶ Audi A6 allroad

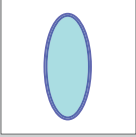
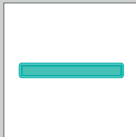
2001 – 2006

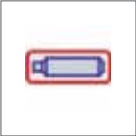

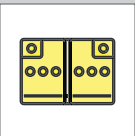
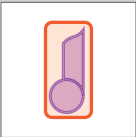
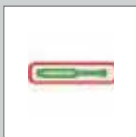
Legend

	Airbag		Reinforcement		Control module
	Gas generator		Rollover protection		Battery
	Pre-tensioner		Gas-pressure damper		Fuel tank

This document is a subject to the copyright of AUDI AG, Ingolstadt. Any duplication, distribution, storage, communication, broadcast and reproduction or transmission of the contents without written approval from AUDI AG is prohibited.



▶ Audi A6 / S6 / RS6

2004 – 2008

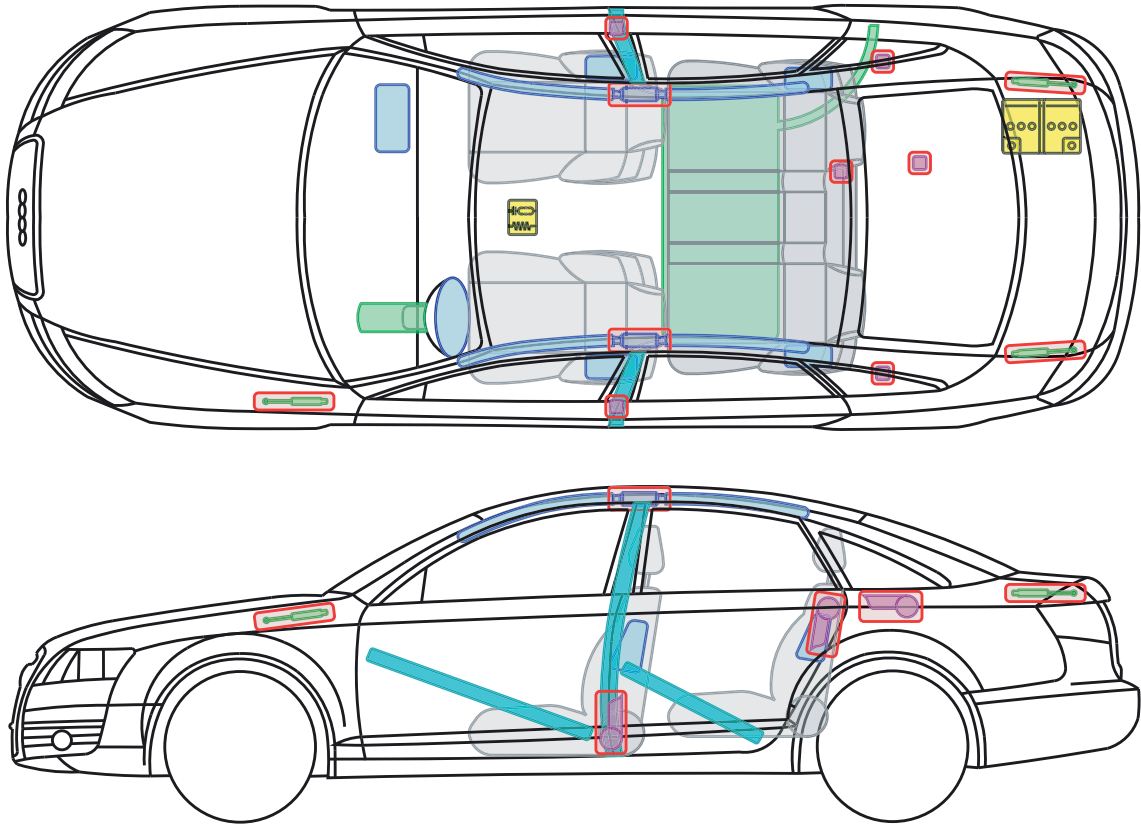

Legend

	Airbag		Reinforcement		Control module
	Gas generator		Rollover protection		Battery
	Pre-tensioner		Gas-pressure damper		Fuel tank

This document is a subject to the copyright of AUDI AG, Ingolstadt. Any duplication, distribution, storage, communication, broadcast and reproduction or transmission of the contents without written approval from AUDI AG is prohibited.



▶ Audi A6 / S6 / RS6

2008 – 2011

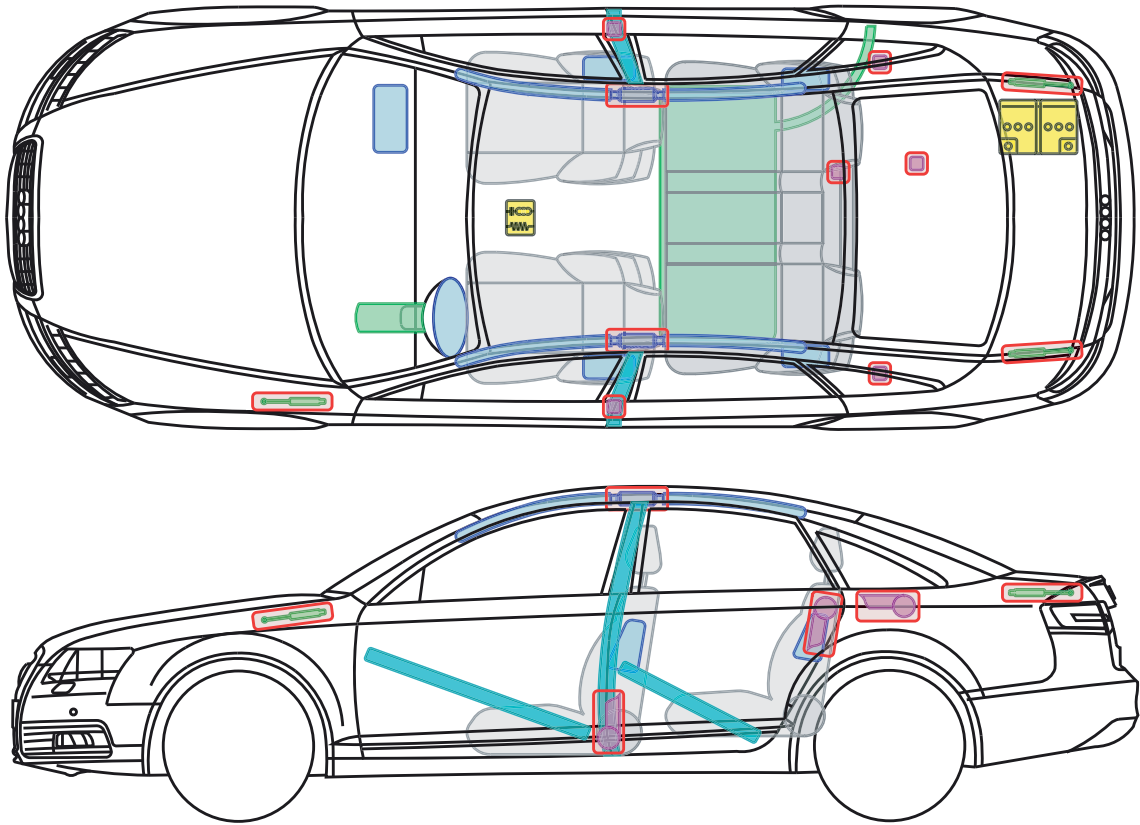

Legend

	Airbag		Reinforcement		Control module
	Gas generator		Rollover protection		Battery
	Pre-tensioner		Gas-pressure damper		Fuel tank

This document is a subject to the copyright of AUDI AG, Ingolstadt. Any duplication, distribution, storage, communication, broadcast and reproduction or transmission of the contents without written approval from AUDI AG is prohibited.



▶ Audi A6 / S6 / RS6 Avant

2004 – 2012

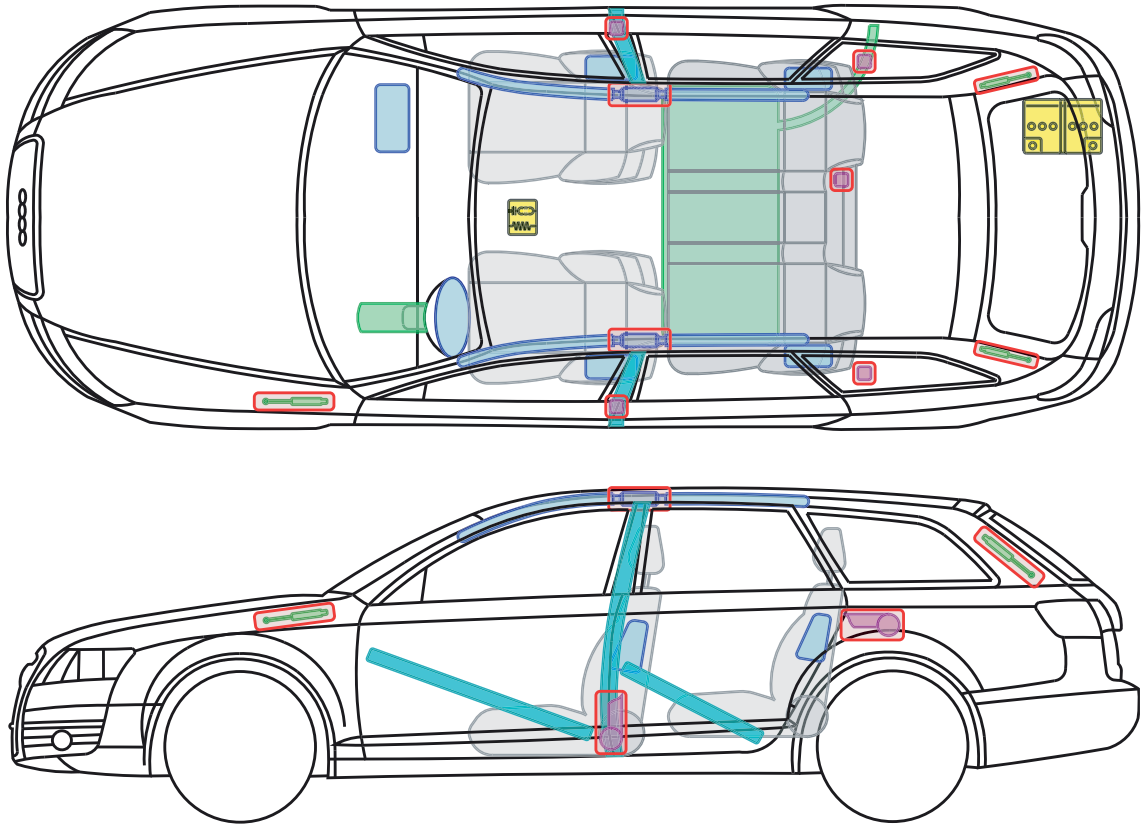

Legend

	Airbag		Reinforce-ment		Control module
	Gas generator		Rollover protection		Battery
	Pre-tensioner		Gas-pressure damper		Fuel tank

This document is a subject to the copyright of AUDI AG, Ingolstadt. Any duplication, distribution, storage, communication, broadcast and reproduction or transmission of the contents without written approval from AUDI AG is prohibited.







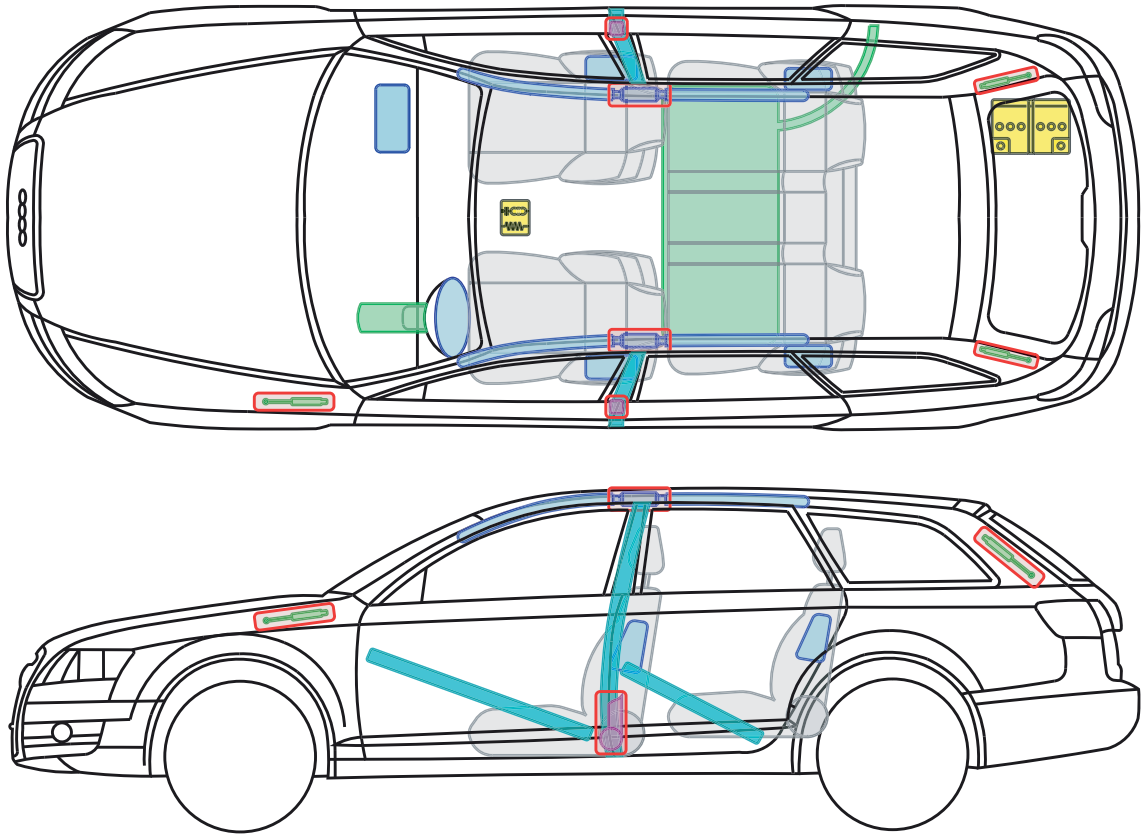

▶ Audi A6 allroad

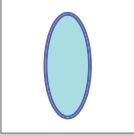
2006 – 2012

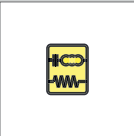
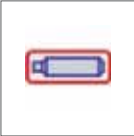

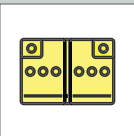
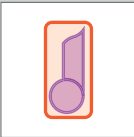
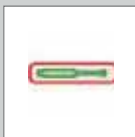
Legend

	Airbag		Reinforcement		Control module
	Gas generator		Rollover protection		Battery
	Pre-tensioner		Gas-pressure damper		Fuel tank

This document is a subject to the copyright of AUDI AG, Ingolstadt. Any duplication, distribution, storage, communication, broadcast and reproduction or transmission of the contents without written approval from AUDI AG is prohibited.





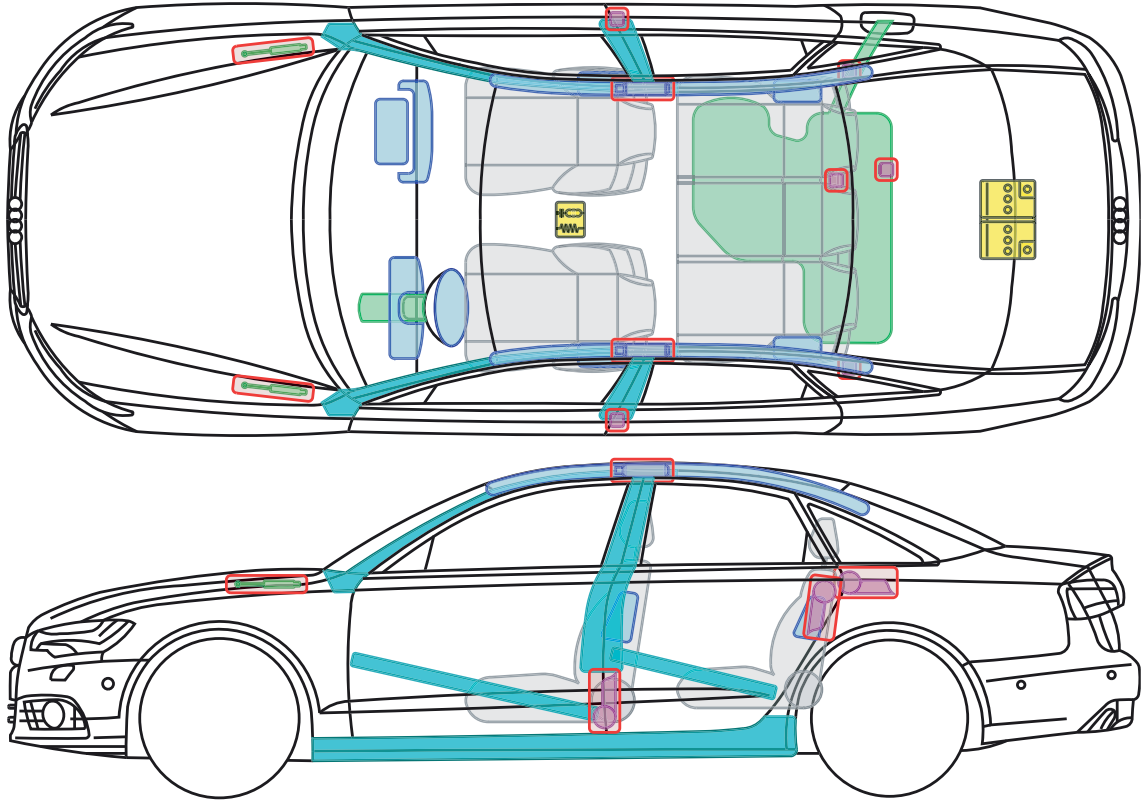

▶ Audi A6 / S6

from 2011

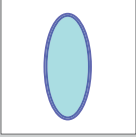
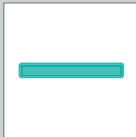
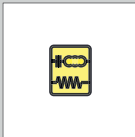
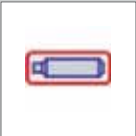

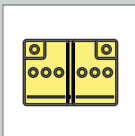
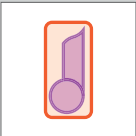
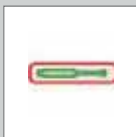
Legend

	Airbag		Reinforcement		Control module
	Gas generator		Rollover protection		Battery
	Pre-tensioner		Gas-pressure damper		Fuel tank

This document is a subject to the copyright of AUDI AG, Ingolstadt. Any duplication, distribution, storage, communication, broadcast and reproduction or transmission of the contents without written approval from AUDI AG is prohibited.





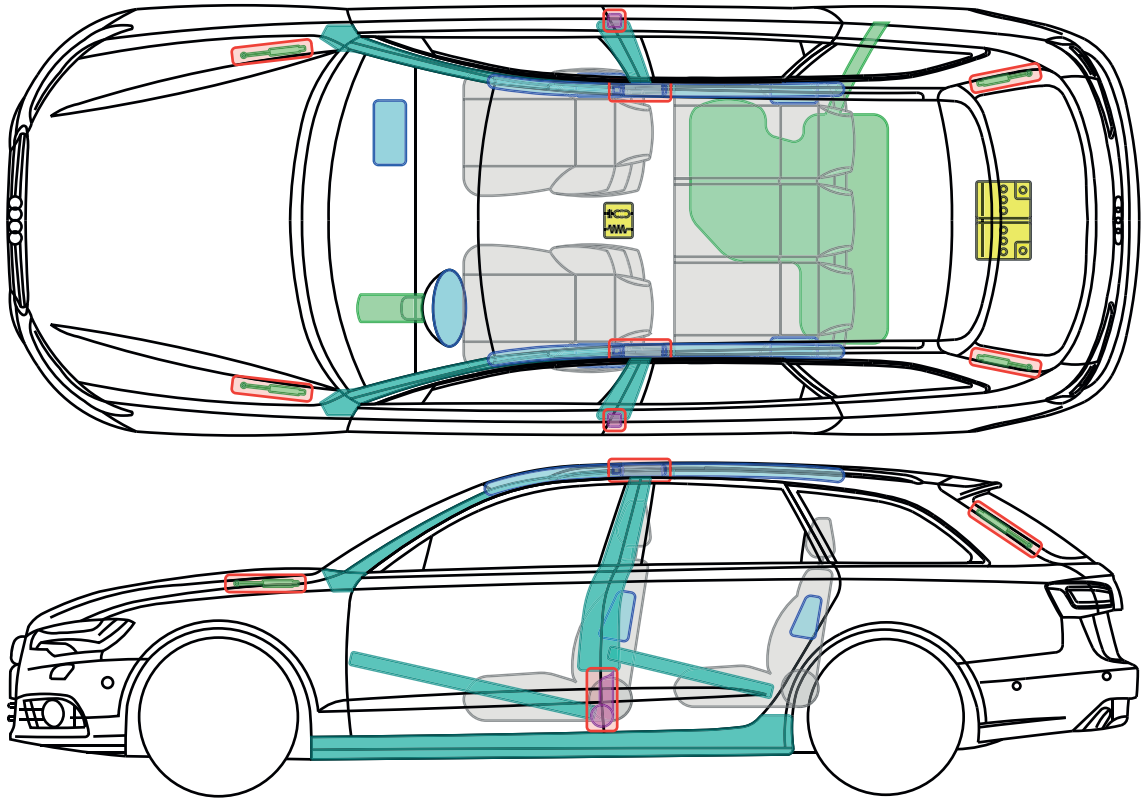

▶ Audi A6 / S6 / RS6 Avant

from 2011

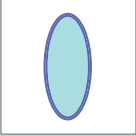
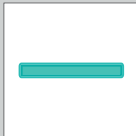
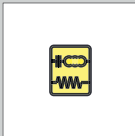
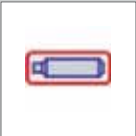

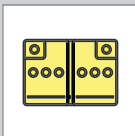
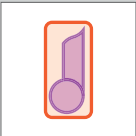
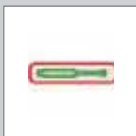
Legend

	Airbag		Reinforce-ment		Control module
	Gas generator		Rollover protection		Battery
	Pretensioner		Gas-pressure damper		Fuel tank

This document is a subject to the copyright of AUDI AG, Ingolstadt. Any duplication, distribution, storage, communication, broadcast and reproduction or transmission of the contents without written approval from AUDI AG is prohibited.







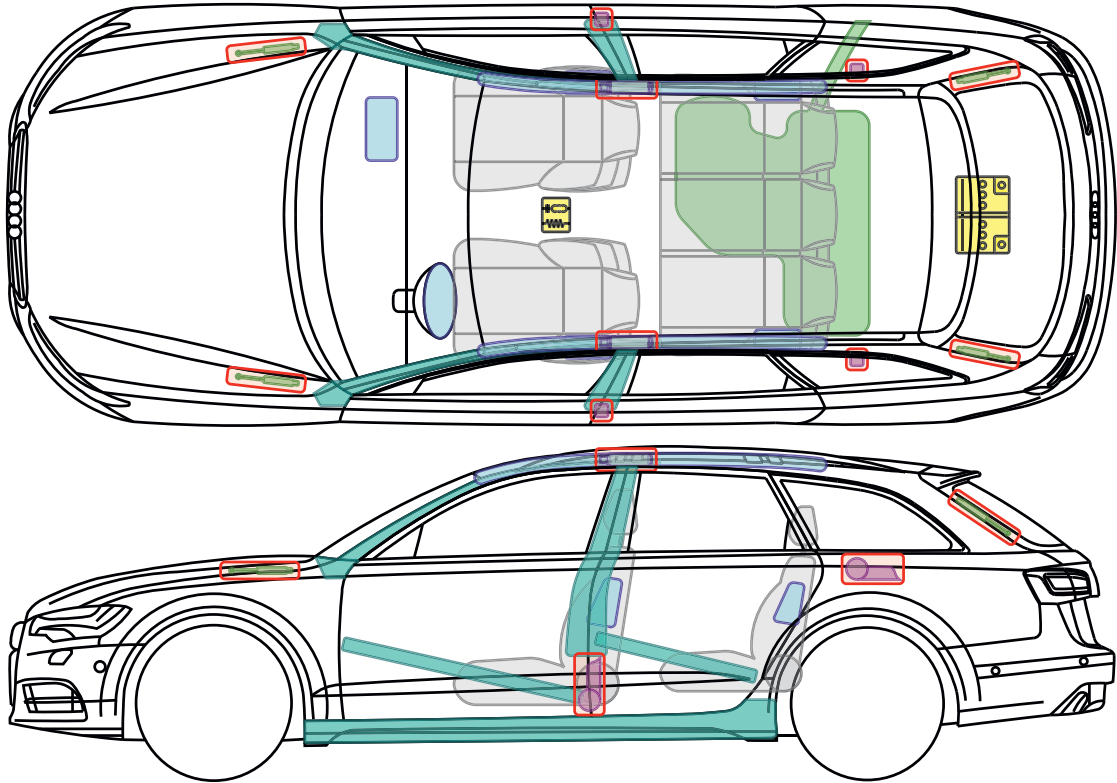

▶ Audi A6 allroad

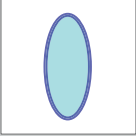
from 2012

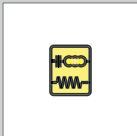
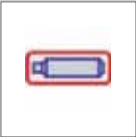

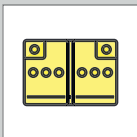
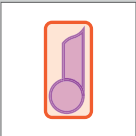
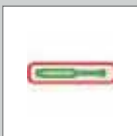
Legend

	Airbag		Reinforcement		Control module
	Gas generator		Rollover protection		Battery
	Pre-tensioner		Gas-pressure damper		Fuel tank

This document is a subject to the copyright of AUDI AG, Ingolstadt. Any duplication, distribution, storage, communication, broadcast and reproduction or transmission of the contents without written approval from AUDI AG is prohibited.







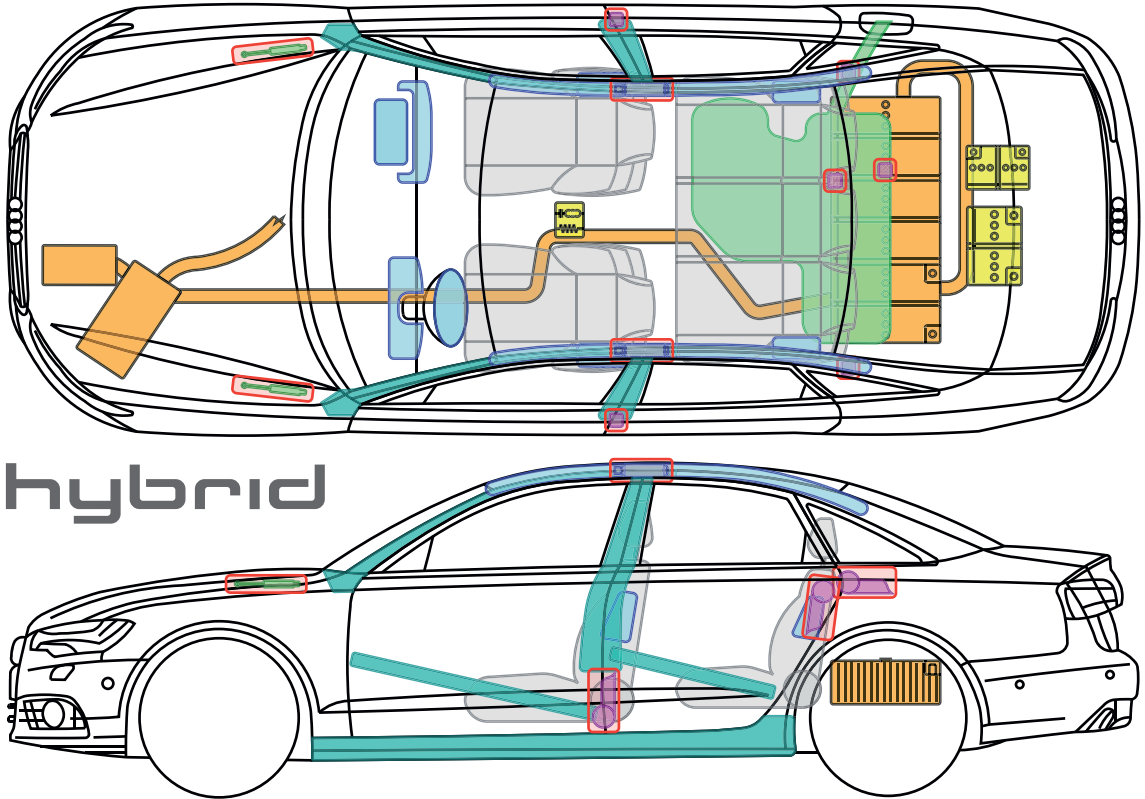

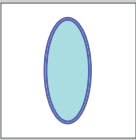
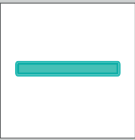

▶ Audi A6 hybrid

from 2012

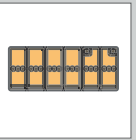
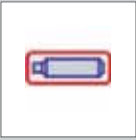

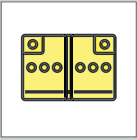
hybrid

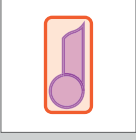
Legend

	Airbag		Reinforcement		Control module		High-voltage battery
	Gas generator		Rollover protection		12 V battery		High-voltage leads/components
	Pretensioner		Gas-pressure damper		Fuel tank		

This document is a subject to the copyright of AUDI AG, Ingolstadt. Any duplication, distribution, storage, communication, broadcast and reproduction or transmission of the contents without written approval from AUDI AG is prohibited.

Audi A6 hybrid

from 2012

Identifying feature

The Audi A6 hybrid can be identified by means of the „hybrid“ logo and the orange cables in the engine compartment.



Hints

⚠ In the case of accidents in which the airbags are deployed, the high-voltage system is deactivated.

In the case of accidents with deployed / undeployed airbags

- ▶ Place Vehicle in Park and set parking brake
- ▶ Switch off the ignition
- ▶ Disconnect the negative terminals of the 12V battery

⚠ The electric motor is silent!



It may not be possible to detect that the car is ready to go by the noises it makes when in operation, as the electric motor is silent. If the large needle in the dial on the left of the instrument cluster (power metre) is not on „OFF“ (for example on the „READY position), you have to expect that the electric motor may run or the internal combustion engine may start automatically.

Switch off the ignition



With the ignition switched on:

Press START ENGINE STOP button without depressing brake pedal.

⚠ Risk of Injury: By pressing the START ENGINE STOP button with depressing brake pedal, the engine starts!



▶ Audi A6 hybrid

from 2012

Disconnect the negative terminals of the 12V batteries

Option A:

Release the luggage compartment floor by means of the screws indicated by the arrows (screwdriver in the car tool kit) Disconnect the ground cables from both 12V batteries (picture on right)

Option B:

Lever up the luggage compartment floor by inserting a crowbar at the point indicated. Lift up the luggage compartment floor. Disconnect the ground cables from both 12V batteries (picture on right)

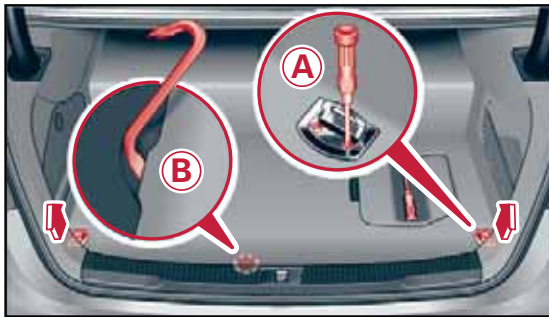

Identification of the high-voltage components

Identification of the high-voltage battery



Identification of the high-voltage battery is located under the luggage compartment floor.

It is a lithium-ion battery.

Identification of the remaining high-voltage components



All the high-voltage leads and the high-voltage connections are provided with orange insulation. These items must not be disconnected or damaged.







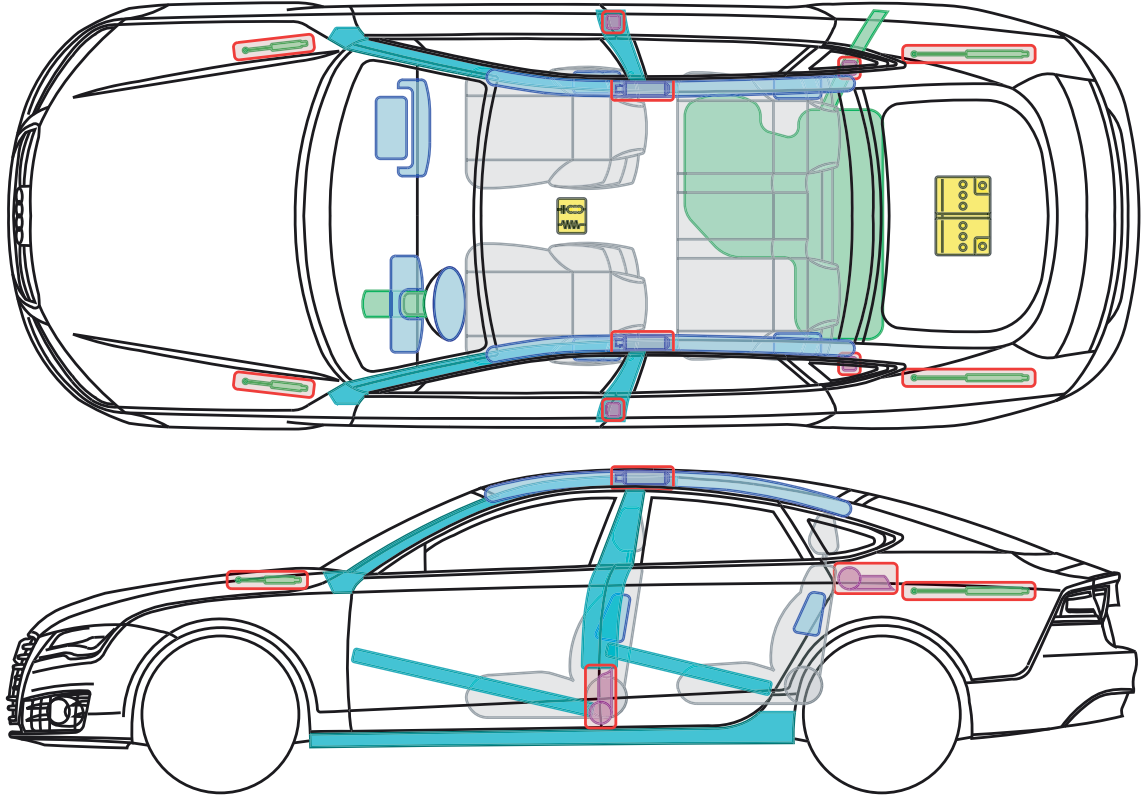

▶ Audi A7 / S7 / RS7 Sportback

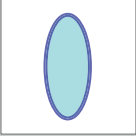
from 2010

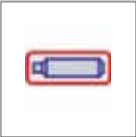

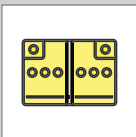
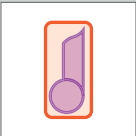
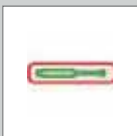
Legend

	Airbag		Reinforcement		Control module
	Gas generator		Rollover protection		Battery
	Pre-tensioner		Gas-pressure damper		Fuel tank





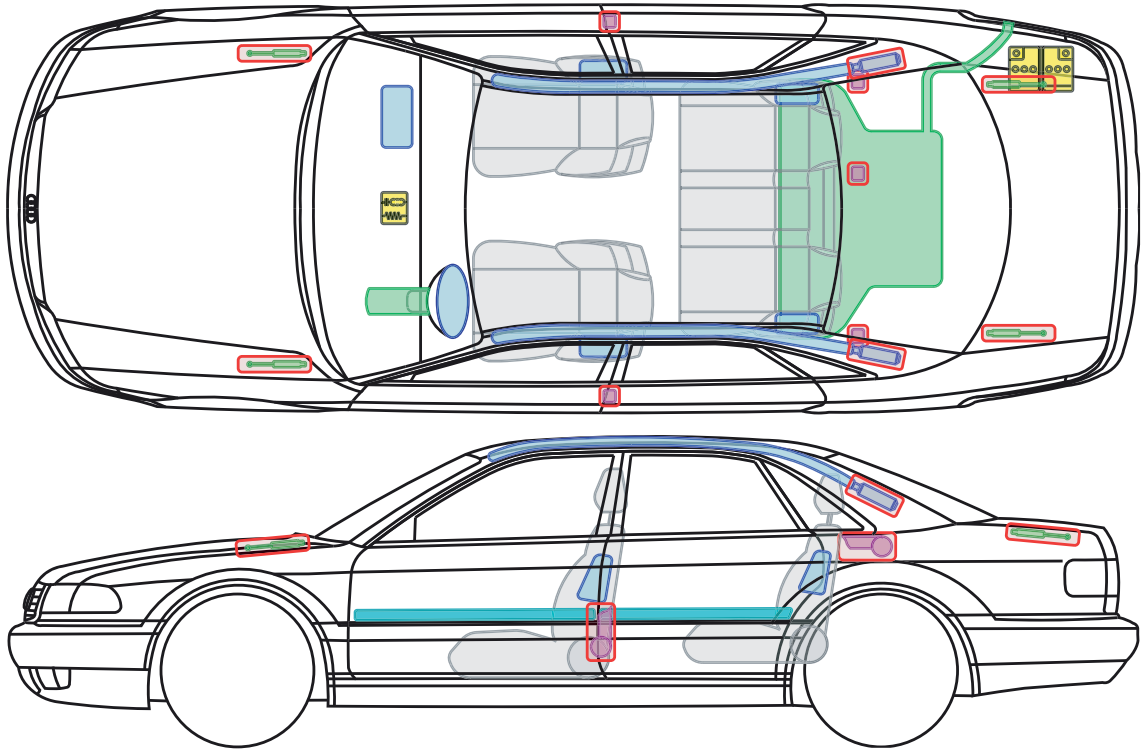

This document is a subject to the copyright of AUDI AG, Ingolstadt. Any duplication, distribution, storage, communication, broadcast and reproduction or transmission of the contents without written approval from AUDI AG is prohibited.

Audi A8 / S8

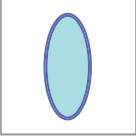
1994 – 2002

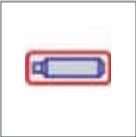

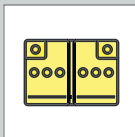
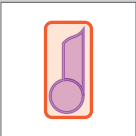
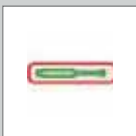
Legend

	Airbag		Reinforcement		Control module
	Gas generator		Rollover protection		Battery
	Pre-tensioner		Gas-pressure damper		Fuel tank

This document is a subject to the copyright of AUDI AG, Ingolstadt. Any duplication, distribution, storage, communication, broadcast and reproduction or transmission of the contents without written approval from AUDI AG is prohibited.





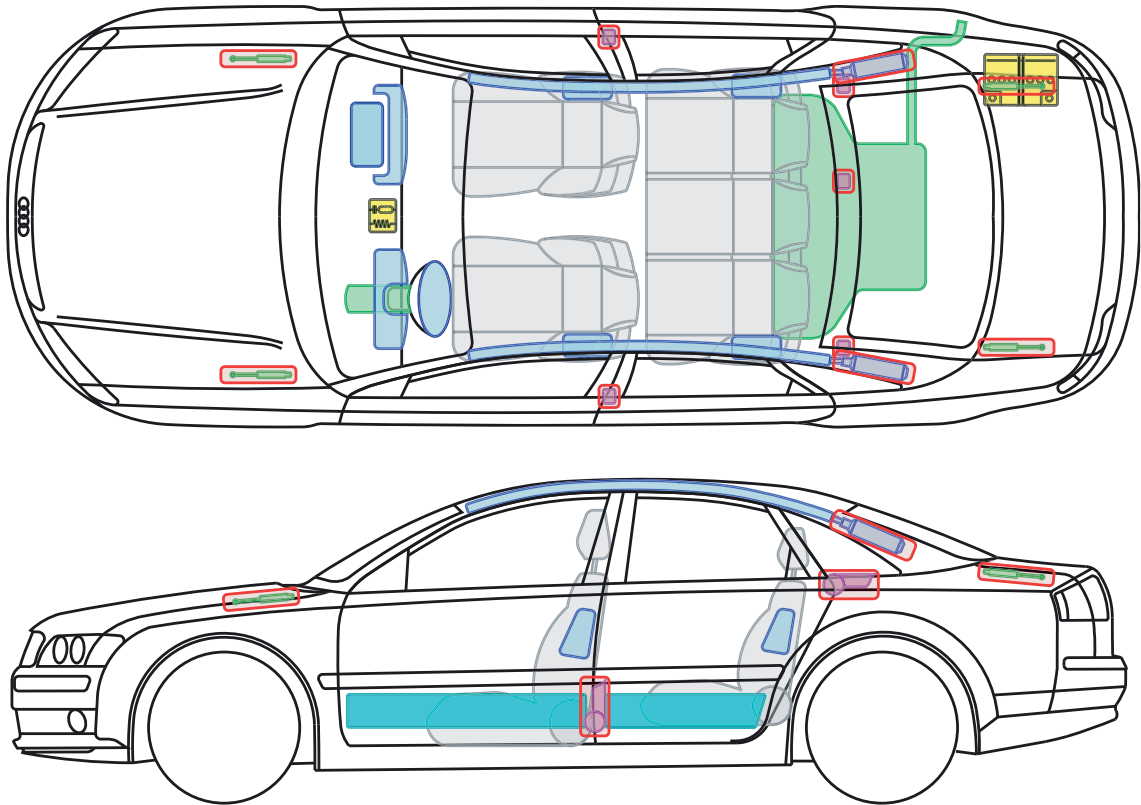

▶ Audi A8 / S8

2002 – 2010

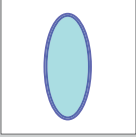
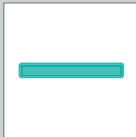
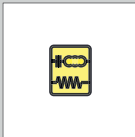
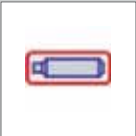

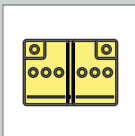
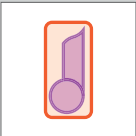
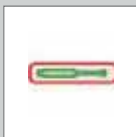
Legend

	Airbag		Reinforcement		Control module
	Gas generator		Rollover protection		Battery
	Pre-tensioner		Gas-pressure damper		Fuel tank

This document is a subject to the copyright of AUDI AG, Ingolstadt. Any duplication, distribution, storage, communication, broadcast and reproduction or transmission of the contents without written approval from AUDI AG is prohibited.



▶ Audi A8 / S8

from 2010

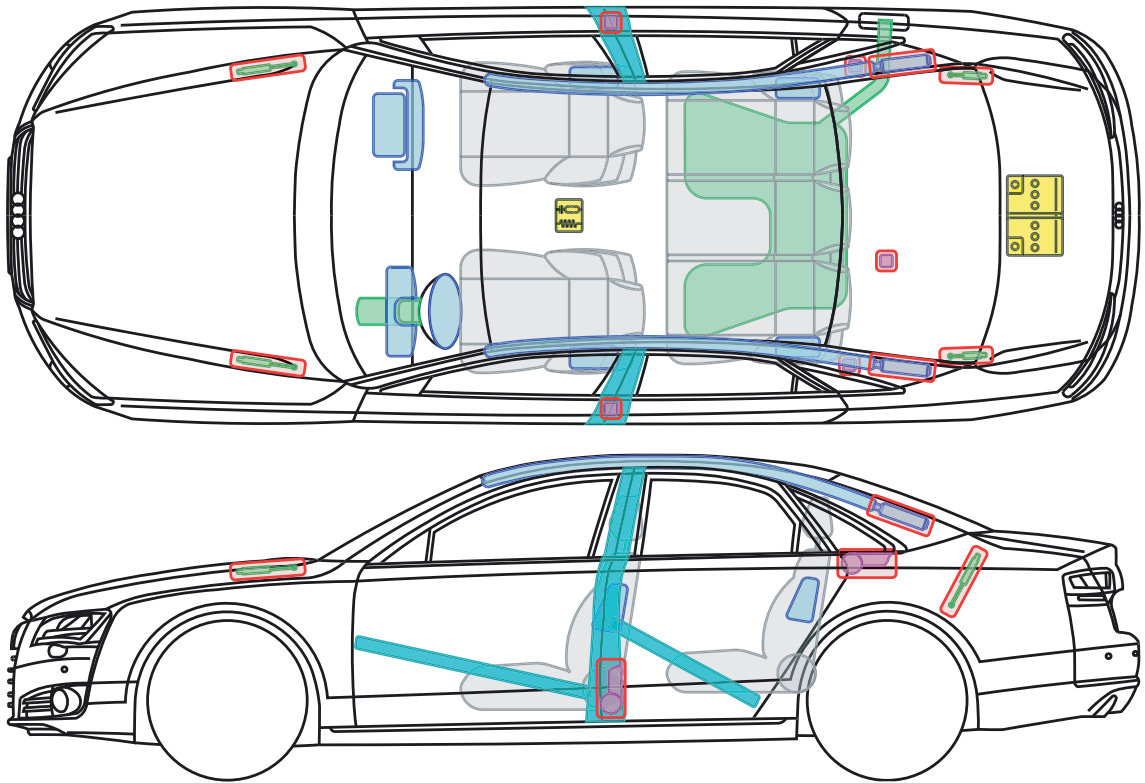

Legend

	Airbag		Reinforcement		Control module
	Gas generator		Rollover protection		Battery
	Pre-tensioner		Gas-pressure damper		Fuel tank

This document is a subject to the copyright of AUDI AG, Ingolstadt. Any duplication, distribution, storage, communication, broadcast and reproduction or transmission of the contents without written approval from AUDI AG is prohibited.



▶ Audi A8 hybrid



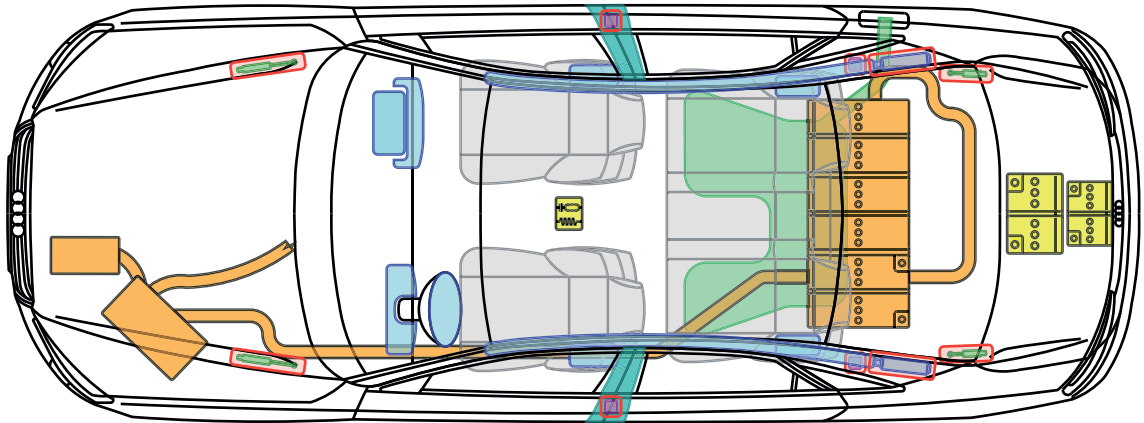



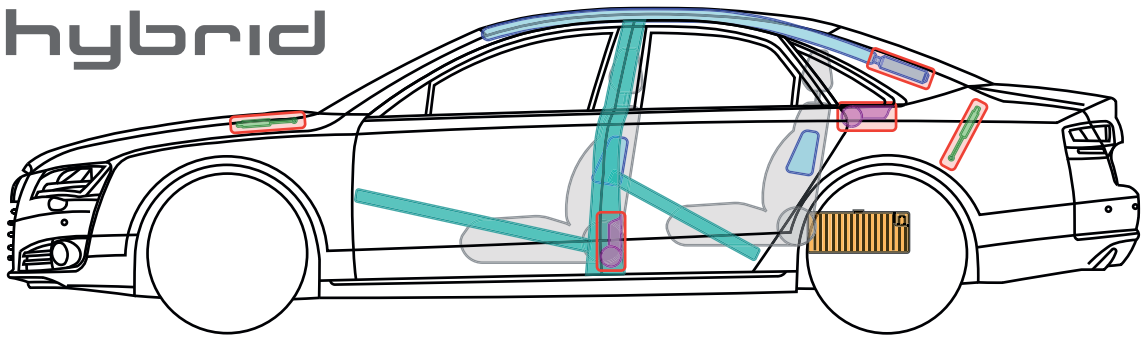

from 2012

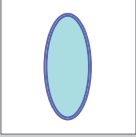

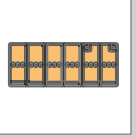
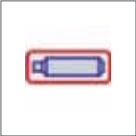
hybrid

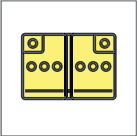

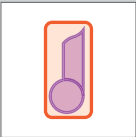
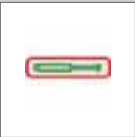
Legend

	Airbag		Reinforcement		Control module		High-voltage battery
	Gas generator		Rollover protection		12 V battery		High-voltage leads/components
	Pretensioner		Gas-pressure damper		Fuel tank		

This document is a subject to the copyright of AUDI AG, Ingolstadt. Any duplication, distribution, storage, communication, broadcast and reproduction or transmission of the contents without written approval from AUDI AG is prohibited.



▶ Audi A8 hybrid

from 2012

Identifying feature

The Audi A8 hybrid can be identified by means of the „hybrid“ logo and the orange cables in the engine compartment.



Hints

⚠ In the case of accidents in which the airbags are deployed, the high-voltage system is deactivated.

In the case of accidents with deployed / undeployed airbags

- ▶ Place Vehicle in Park and set parking brake
- ▶ Switch off the ignition
- ▶ Disconnect the negative terminals of the 12V battery

⚠ The electric motor is silent!



It may not be possible to detect that the car is ready to go by the noises it makes when in operation, as the electric motor is silent. If the large needle in the dial on the left of the instrument cluster (power metre) is not on „OFF“ (for example on the „READY position), you have to expect that the electric motor may run or the internal combustion engine may start automatically.

Switch off the ignition



With the ignition switched on:
Press START ENGINE STOP button without depressing brake pedal.

⚠ Risk of Injury: By pressing the START ENINGE STOP button with depressing brake pedal, the engine starts!



▶ Audi A8 hybrid

from 2012

Disconnect the negative terminals of the 12 V batteries

Lever up the luggage compartment floor. Lift up the tool box element. Disconnect the ground cables from both 12 V batteries (picture on right).

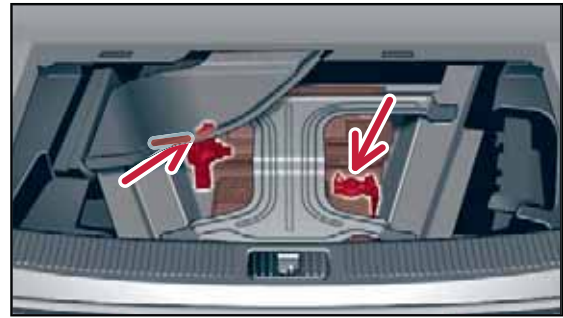
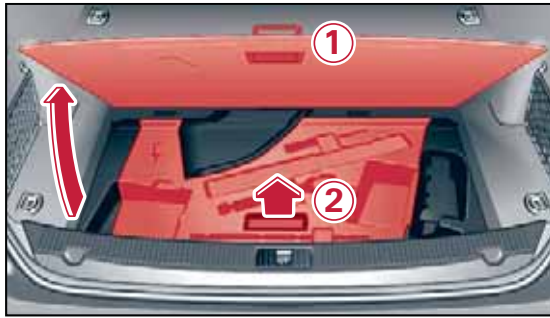

Identification of the high-voltage components

Identification of the high-voltage battery



Identification of the high-voltage battery is located under the luggage compartment floor.

It is a lithium-ion battery.

Identification of the remaining high-voltage components



All the high-voltage leads and the high-voltage connections are provided with orange insulation. These items must not be disconnected or damaged.







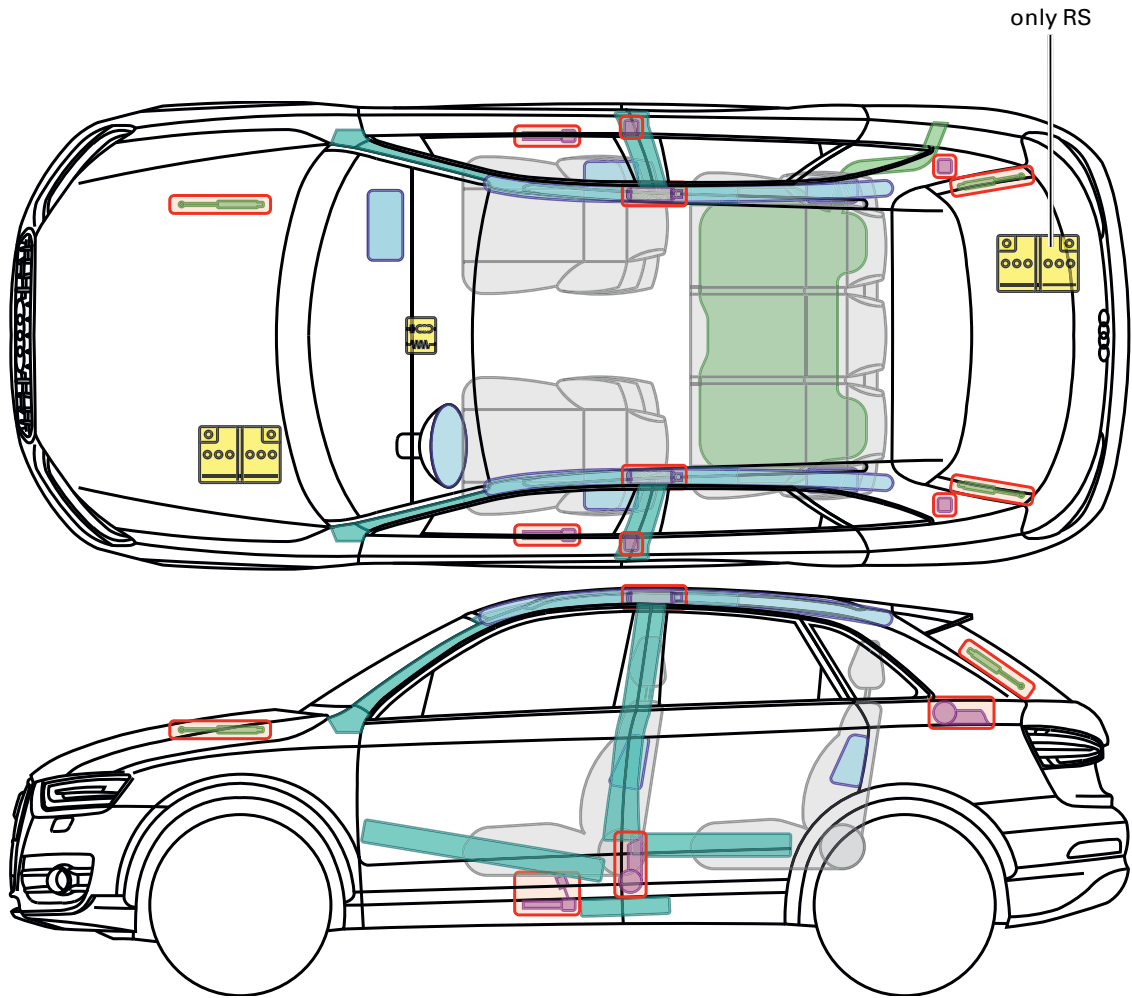

▶ Audi Q3 / RS Q3

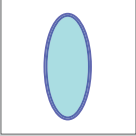
from 2011

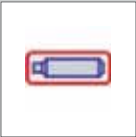

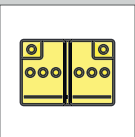
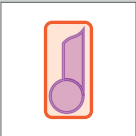
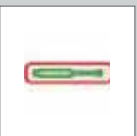
Legend

	Airbag		Reinforcement		Control module
	Gas generator		Rollover protection		Battery
	Pre-tensioner		Gas-pressure damper		Fuel tank

This document is a subject to the copyright of AUDI AG, Ingolstadt. Any duplication, distribution, storage, communication, broadcast and reproduction or transmission of the contents without written approval from AUDI AG is prohibited.







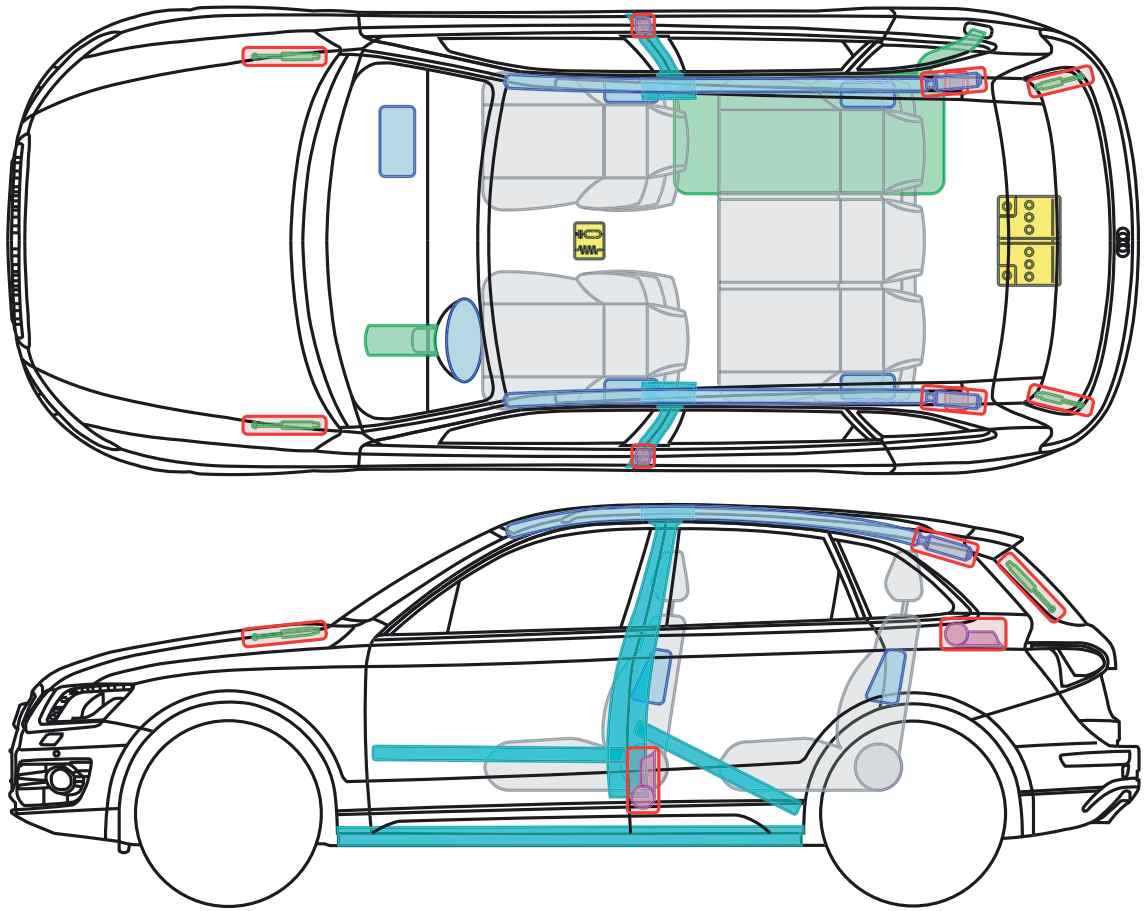

▶ Audi Q5 / SQ5

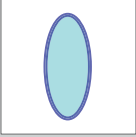
from 2008

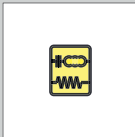
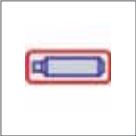

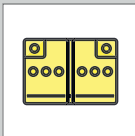
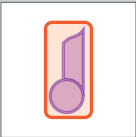
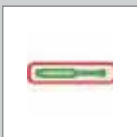
Legend

	Airbag		Reinforcement		Control module
	Gas generator		Rollover protection		Battery
	Pre-tensioner		Gas-pressure damper		Fuel tank

This document is a subject to the copyright of AUDI AG, Ingolstadt. Any duplication, distribution, storage, communication, broadcast and reproduction or transmission of the contents without written approval from AUDI AG is prohibited.



▶ Audi Q5 hybrid quattro



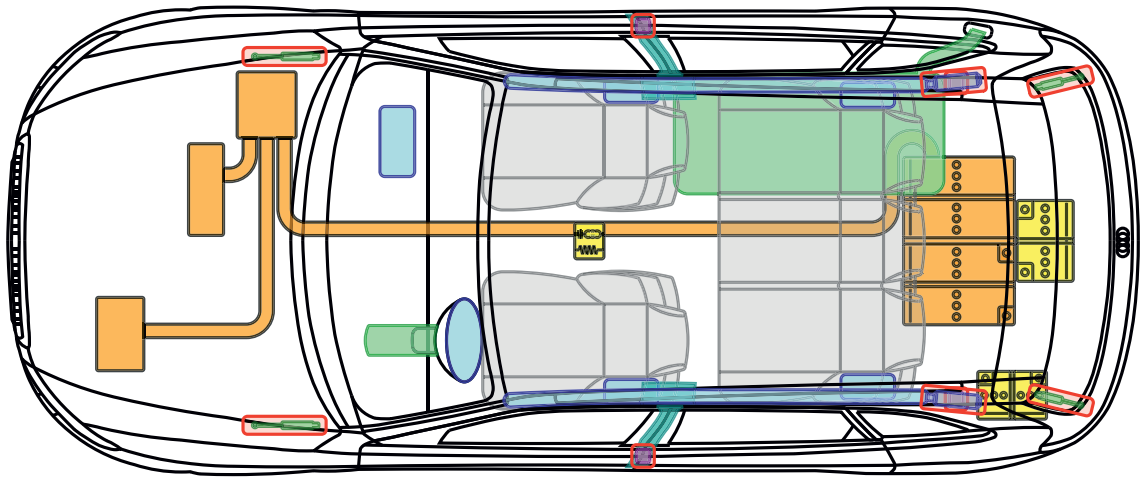



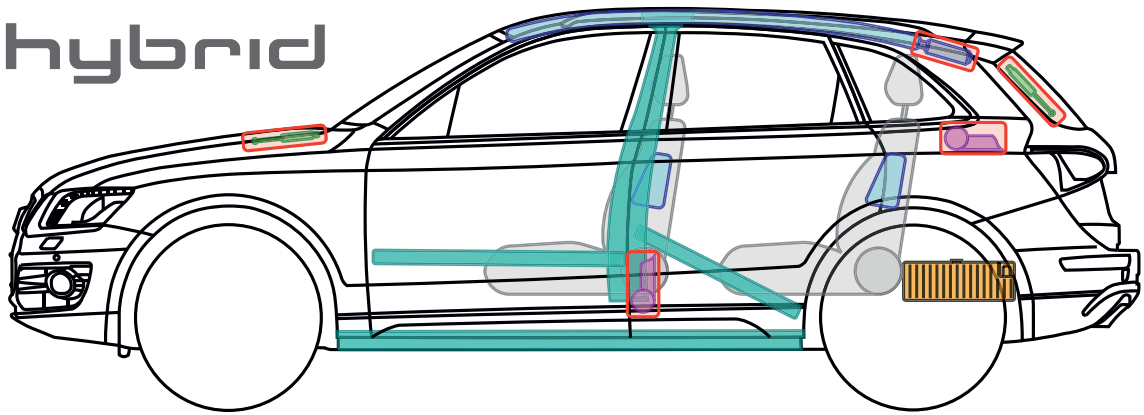

from 2011

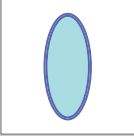

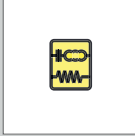
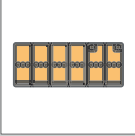
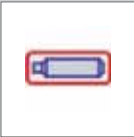
hybrid

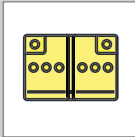

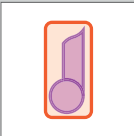
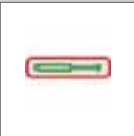
Legend

	Airbag		Reinforcement		Control module		High-voltage battery
	Gas generator		Rollover protection		12 V battery		High-voltage leads/components
	Pretensioner		Gas-pressure damper		Fuel tank		

This document is a subject to the copyright of AUDI AG, Ingolstadt. Any duplication, distribution, storage, communication, broadcast and reproduction or transmission of the contents without written approval from AUDI AG is prohibited.

▶ Audi Q5 hybrid quattro

from 2011

Identifying feature

The Audi Q5 hybrid quattro can be identified by means of the „hybrid“ logo.



Hints

⚠ In the case of accidents in which the airbags are deployed, the high-voltage system is deactivated.

In the case of accidents with deployed / undeployed airbags

- ▶ Place Vehicle in Park and set parking brake
- ▶ Switch off the ignition
- ▶ Disconnect the negative terminals of the 12V battery

⚠ The electric motor is silent!



It may not be possible to detect that the car is ready to go by the noises it makes when in operation, as the electric motor is silent. If the large needle in the dial on the left of the instrument cluster (power metre) is not on „OFF“ (for example on the „READY position), you have to expect that the electric motor may run or the internal combustion engine may start automatically.

Switch off the ignition



With the ignition switched on and the key in the ignition:
Switch off the ignition by pressing the key into the ignition lock **without** depressing brake pedal. Pull out the key.



With the ignition switched on and the key not in the ignition (possible with the convenience key):
Press START ENGINE STOP button **without** depressing brake pedal. If possible, take the convenience key outside the transmission range of the vehicle (5 meter).

⚠ Risk of Injury: By pressing the key / the START ENINGE STOP button with depressing brake pedal, the engine starts!



▶ Audi Q5 hybrid quattro

from 2011

Disconnect the negative terminals of the 12V batteries

Option A:

Release the luggage compartment floor by means of the screws indicated by the arrows (screwdriver in the car tool kit) Disconnect the ground cables from both 12V batteries (picture on right)

Option B:

Lever up the luggage compartment floor by inserting a crowbar at the points indicated. Lift up the luggage compartment floor. Disconnect the ground cables from both 12V batteries (picture on right)



Identification of the high-voltage components

Identification of the high-voltage battery



Identification of the The high-voltage battery is located under the luggage compartment floor.

It is a lithium-ion battery.

Identification of the remaining high-voltage components



All the high-voltage leads and the high-voltage connections are provided with orange insulation. These items must not be disconnected or damaged.







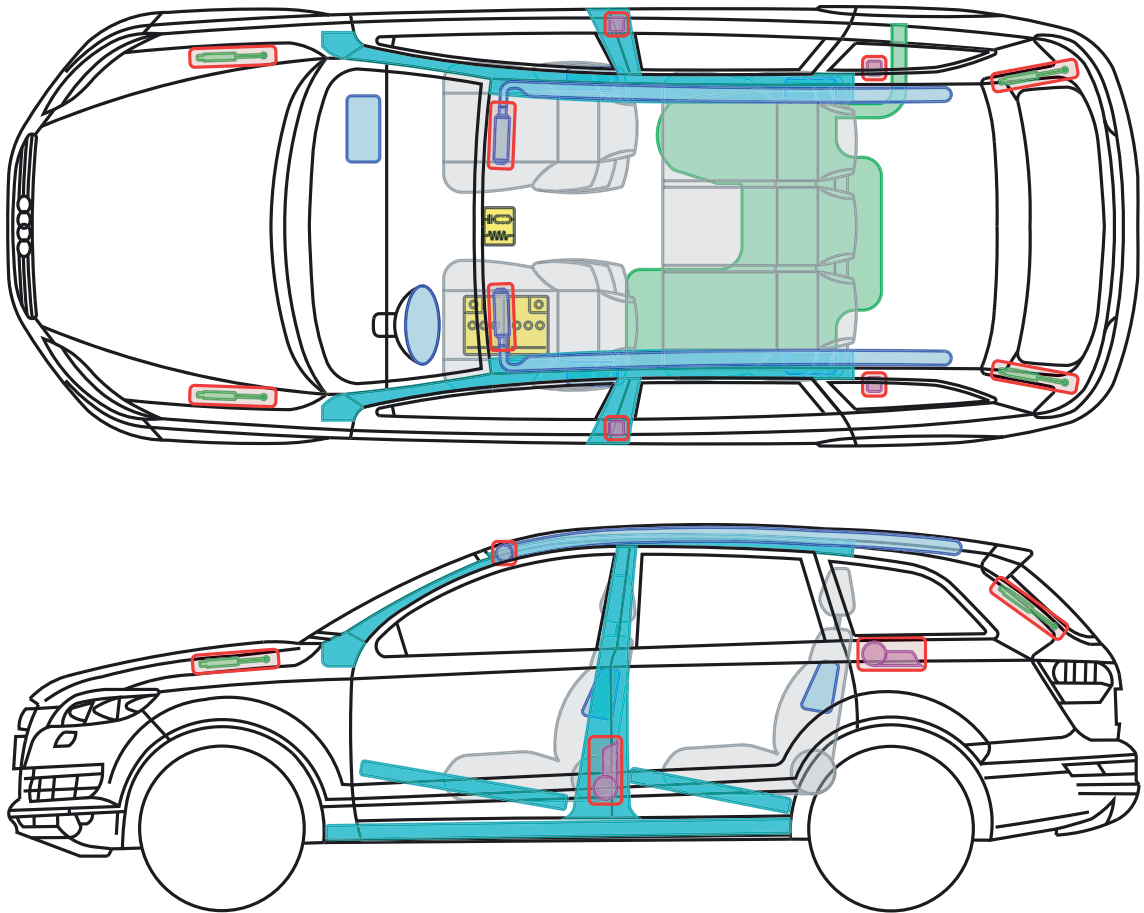

Audi Q7

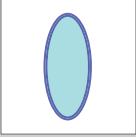
from 2006

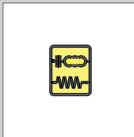
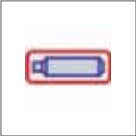

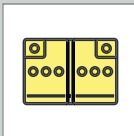
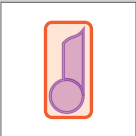
Legend

	Airbag		Reinforcement		Control module
	Gas generator		Rollover protection		Battery
	Pre-tensioner		Gas-pressure damper		Fuel tank

This document is a subject to the copyright of AUDI AG, Ingolstadt. Any duplication, distribution, storage, communication, broadcast and reproduction or transmission of the contents without written approval from AUDI AG is prohibited.







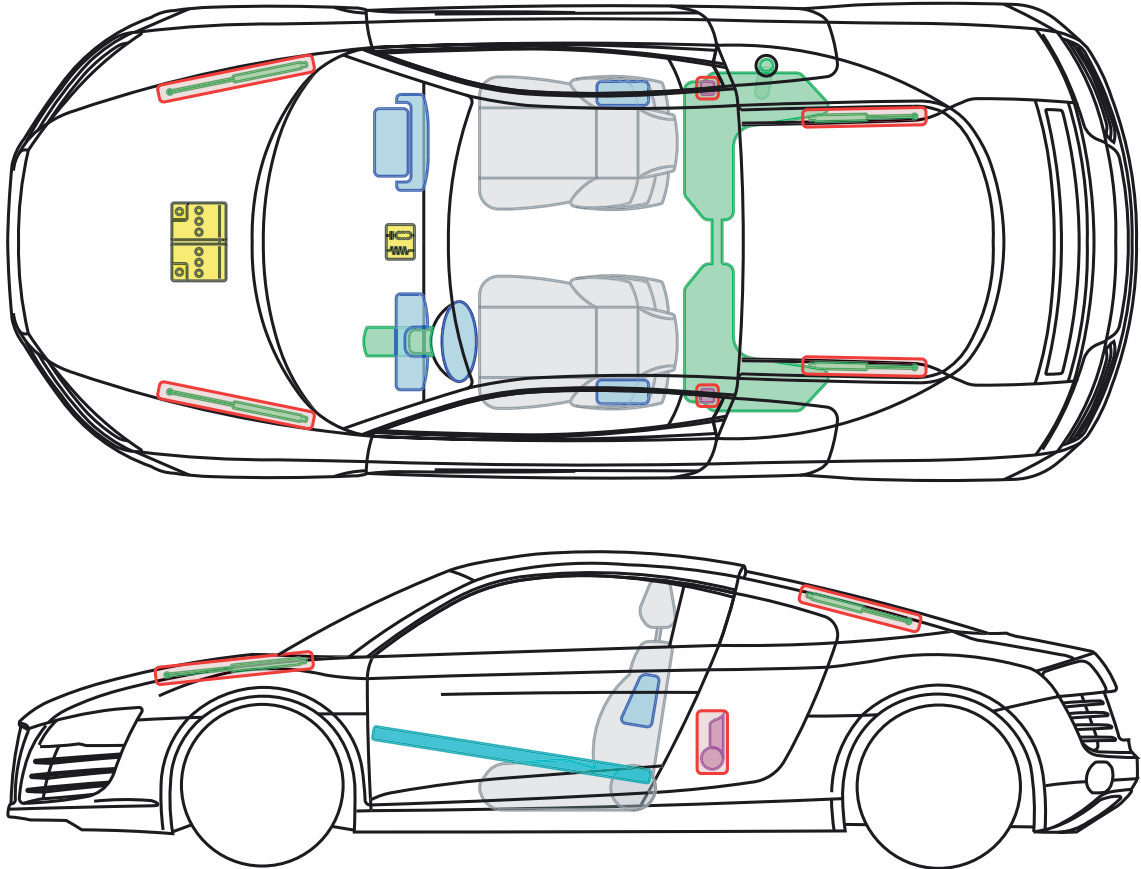

Audi R8

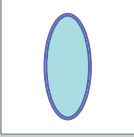
from 2007

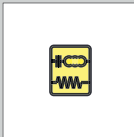
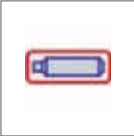

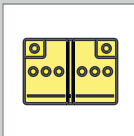
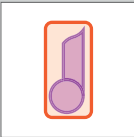
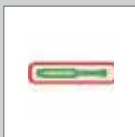
Legend

	Airbag		Reinforce-ment		Control module
	Gas generator		Rollover protection		Battery
	Pre-tensioner		Gas-pressure damper		Fuel tank

This document is a subject to the copyright of AUDI AG, Ingolstadt. Any duplication, distribution, storage, communication, broadcast and reproduction or transmission of the contents without written approval from AUDI AG is prohibited.







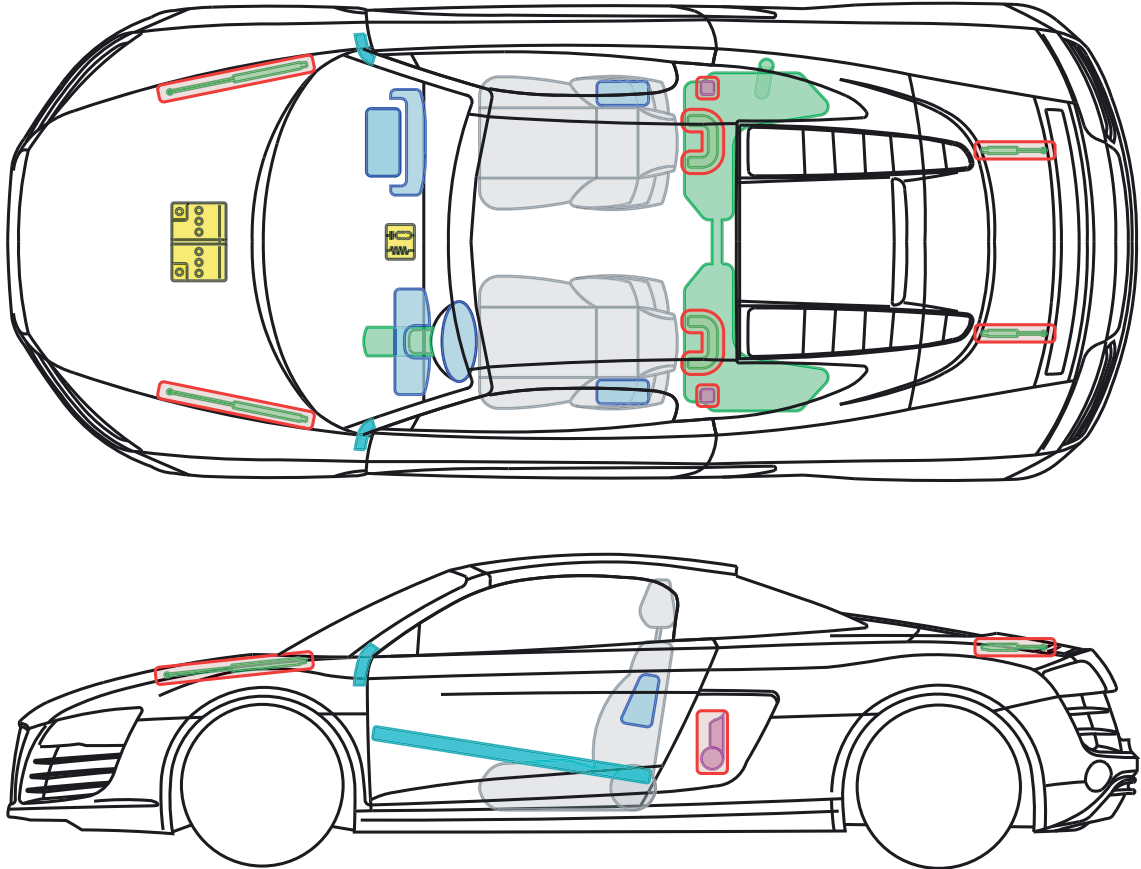

▶ Audi R8 Spyder

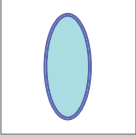
from 2010

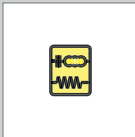
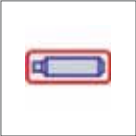

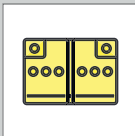
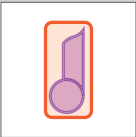
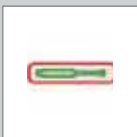
Legend

	Airbag		Reinforcement		Control module
	Gas generator		Rollover protection		Battery
	Pre-tensioner		Gas-pressure damper		Fuel tank

This document is a subject to the copyright of AUDI AG, Ingolstadt. Any duplication, distribution, storage, communication, broadcast and reproduction or transmission of the contents without written approval from AUDI AG is prohibited.







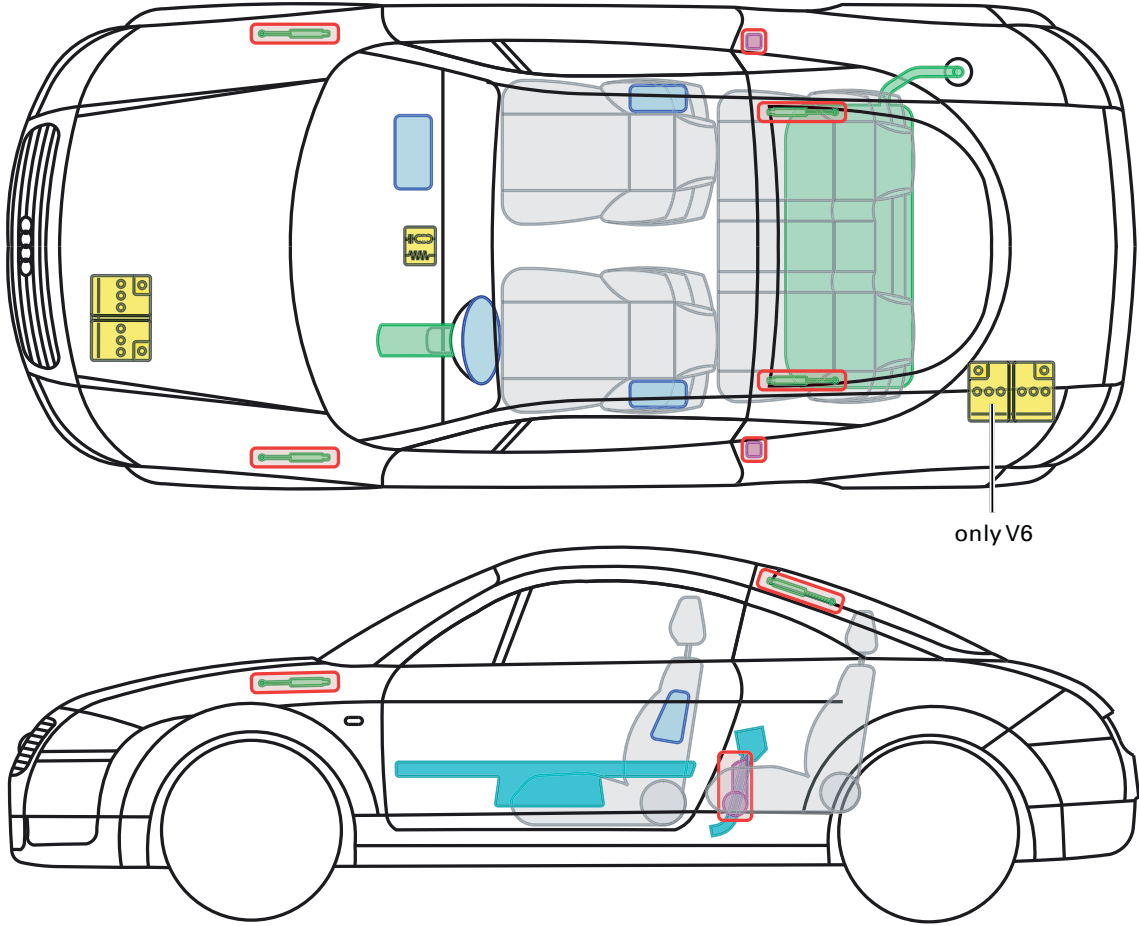

▶ Audi TT Coupé

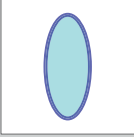
1998 – 2006

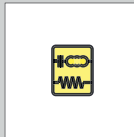
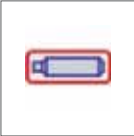

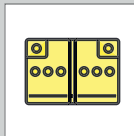
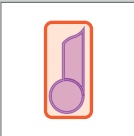
Legend

	Airbag		Reinforcement		Control module
	Gas generator		Rollover protection		Battery
	Pretensioner		Gas-pressure damper		Fuel tank

This document is a subject to the copyright of AUDI AG, Ingolstadt. Any duplication, distribution, storage, communication, broadcast and reproduction or transmission of the contents without written approval from AUDI AG is prohibited.





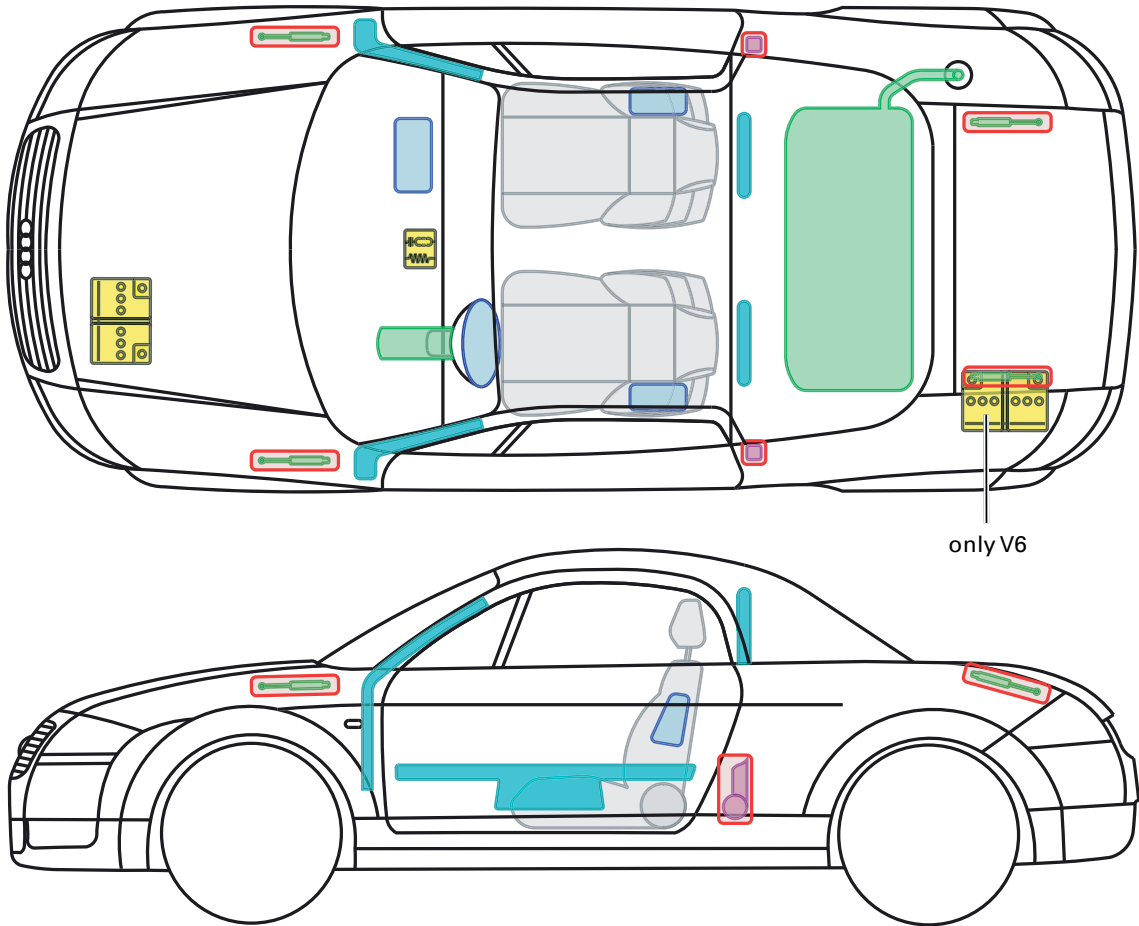

▶ Audi TT Roadster

1999 – 2006

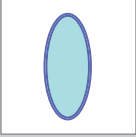
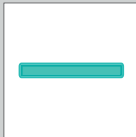
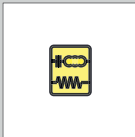
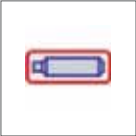

only V6

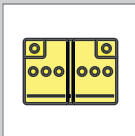
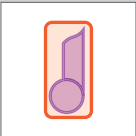
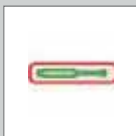
Legend

	Airbag		Reinforce-ment		Control module
	Gas generator		Rollover protection		Battery
	Pre-tensioner		Gas-pressure damper		Fuel tank

This document is a subject to the copyright of AUDI AG, Ingolstadt. Any duplication, distribution, storage, communication, broadcast and reproduction or transmission of the contents without written approval from AUDI AG is prohibited.







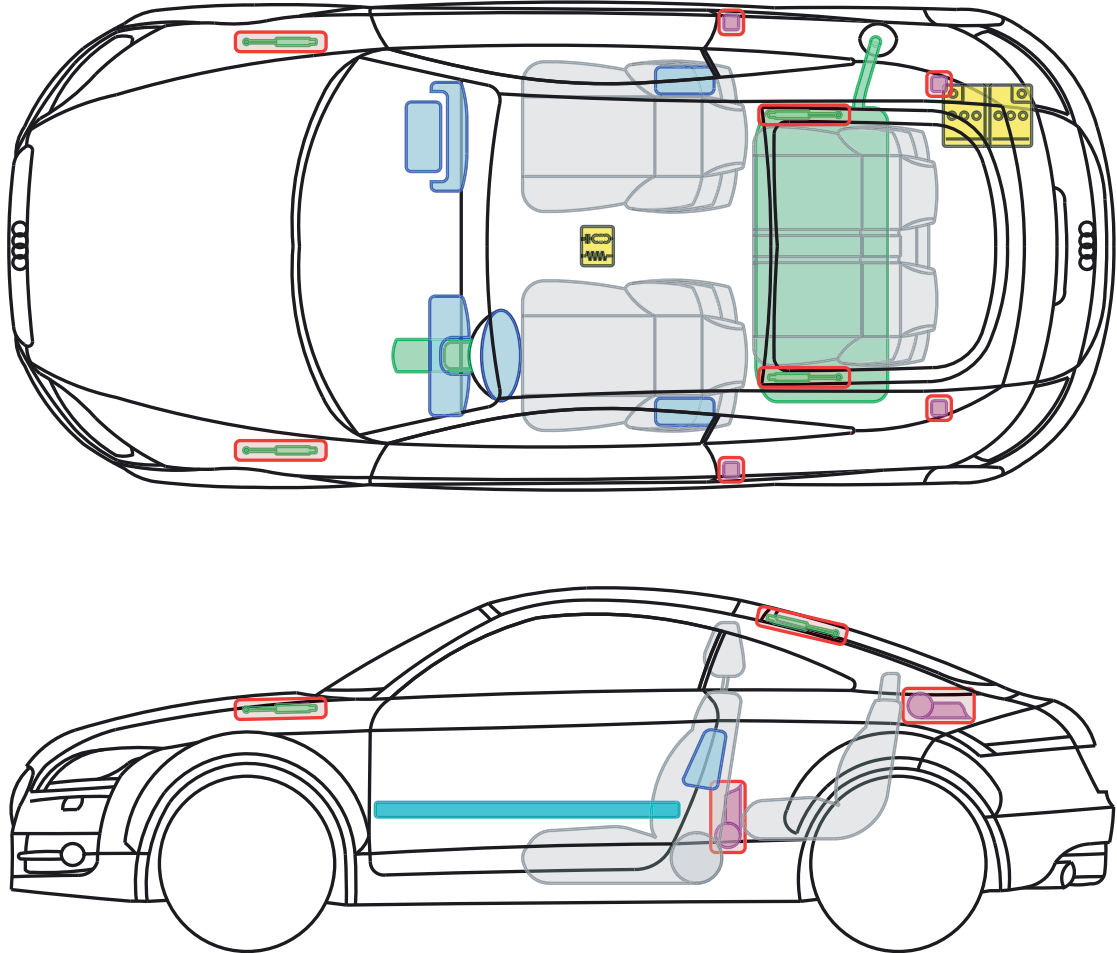

▶ Audi TT / TTS / TTRS Coupé

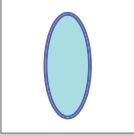
2006 – 2014

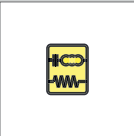
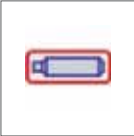

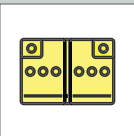
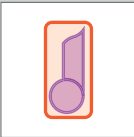
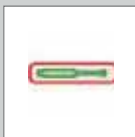
Legend

	Airbag		Reinforcement		Control module
	Gas generator		Rollover protection		Battery
	Pre-tensioner		Gas-pressure damper		Fuel tank

This document is a subject to the copyright of AUDI AG, Ingolstadt. Any duplication, distribution, storage, communication, broadcast and reproduction or transmission of the contents without written approval from AUDI AG is prohibited.



Audi TT / TTS / TTRS Roadster

2007 – 2014

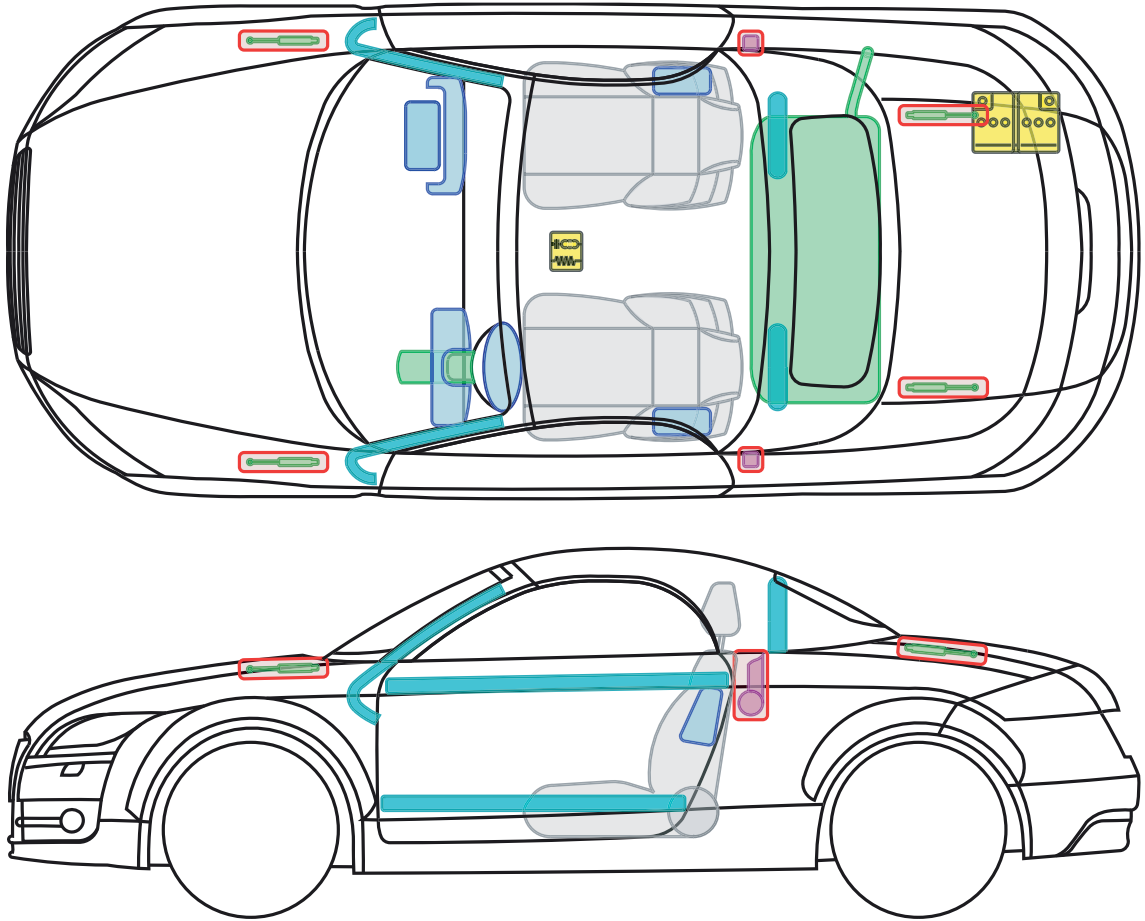

Legend

	Airbag		Reinforcement		Control module
	Gas generator		Roll-over protection		Battery
	Pretensioner		Gas-pressure damper		Fuel tank

This document is a subject to the copyright of AUDI AG, Ingolstadt. Any duplication, distribution, storage, communication, broadcast and reproduction or transmission of the contents without written approval from AUDI AG is prohibited.







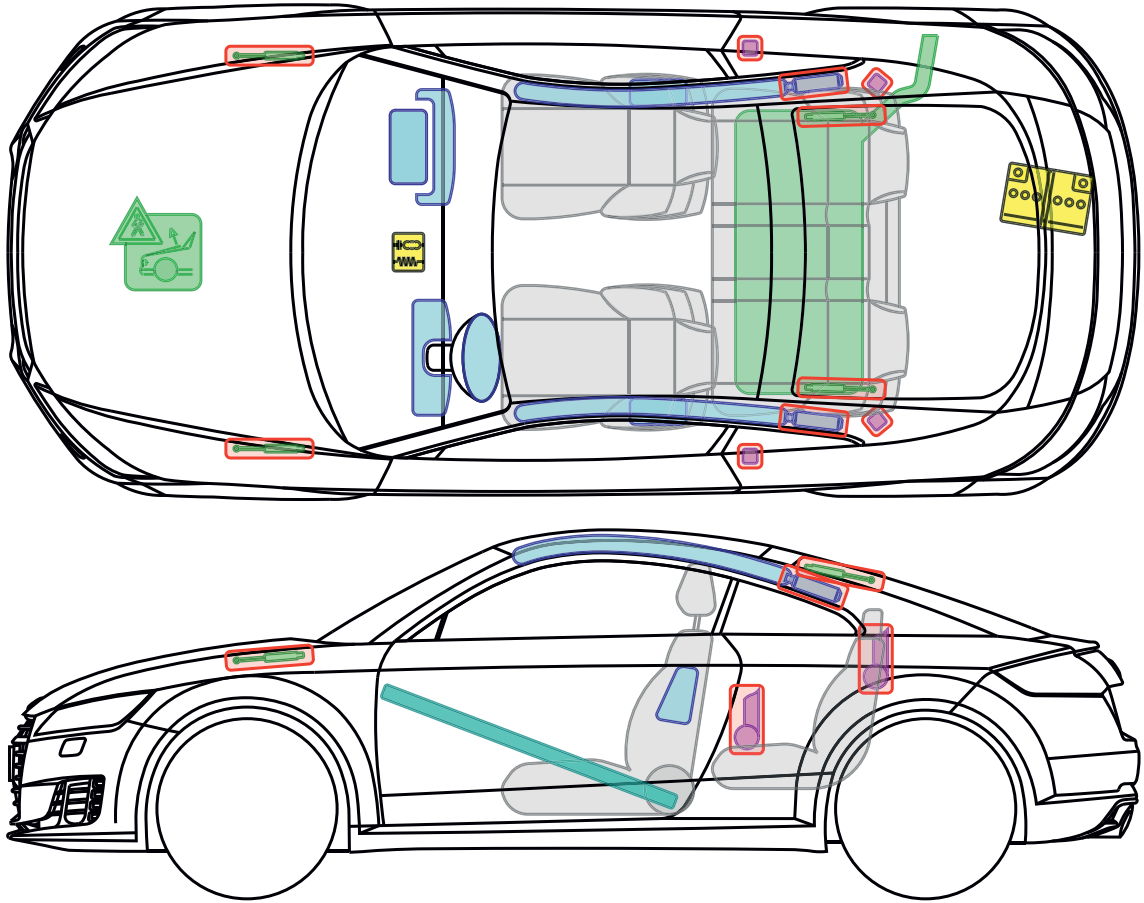

▶ Audi TT / TTS Coupé

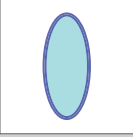
from 2014

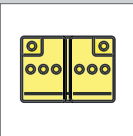
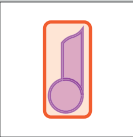

Legende

	Airbag		Karosserieverstärkung		Steuergerät		Fußgängerschutzsystem
	Gasgenerator		Überrollschutz		12V-Batterie		
	Gurtstraffer		Gasdruckdämpfer		Kraftstofftank		

This document is a subject to the copyright of AUDI AG, Ingolstadt. Any duplication, distribution, storage, communication, broadcast and reproduction or transmission of the contents without written approval from AUDI AG is prohibited.







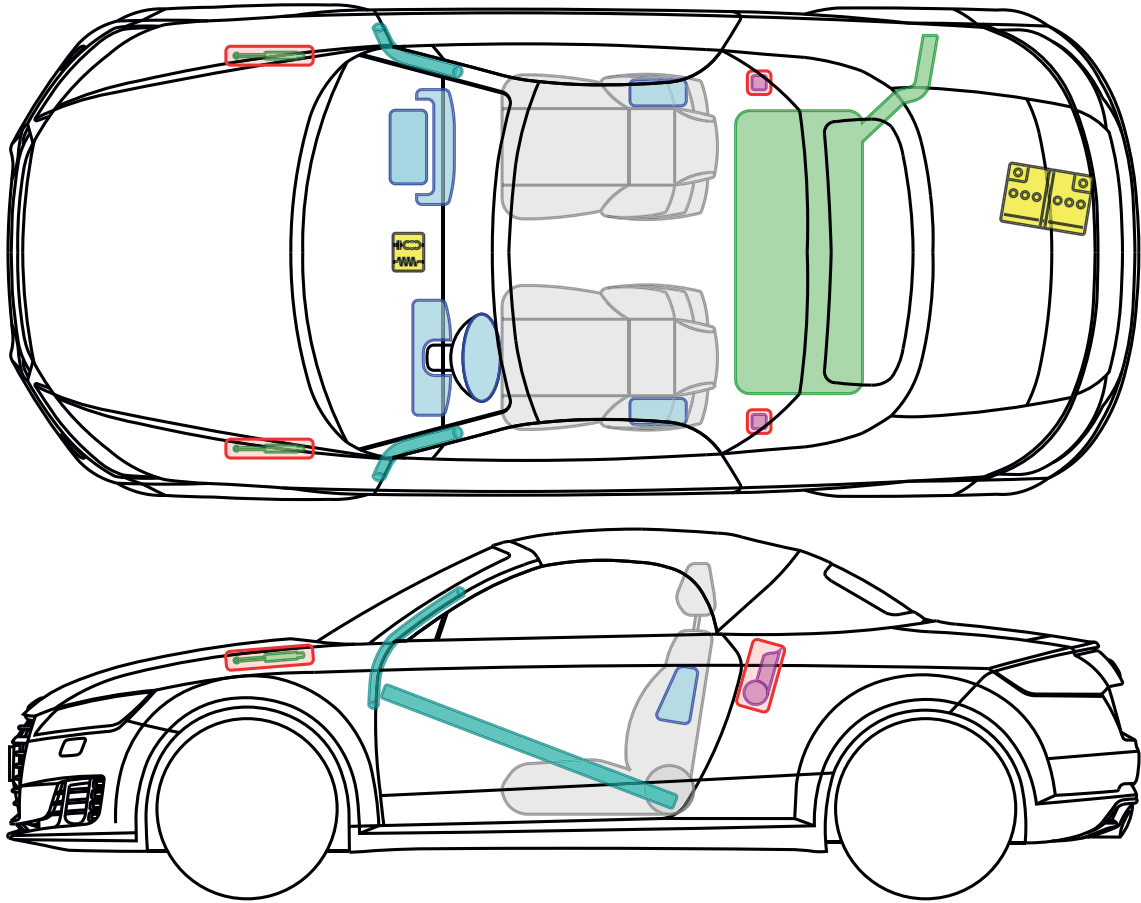

▶ Audi TT / TTS Roadster

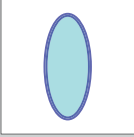
from 2014

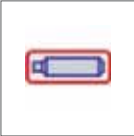

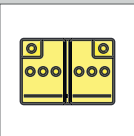
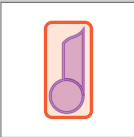
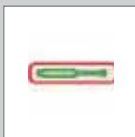
Legend

	Airbag		Reinforcement		Control module
	Gas generator		Rollover protection		Battery
	Pretensioner		Gas-pressure damper		Fuel tank

This document is a subject to the copyright of AUDI AG, Ingolstadt. Any duplication, distribution, storage, communication, broadcast and reproduction or transmission of the contents without written approval from AUDI AG is prohibited.